

RX 20 Technical Data

Electric Forklift Truck



RX 20-14C/Li-Ion

RX 20-16C/Li-Ion

RX 20-16/Li-Ion

RX 20-16L/Li-Ion

RX 20-18/Li-Ion

RX 20-18L/Li-Ion

RX 20-20L/Li-Ion

RX 20-16P/Li-Ion

RX 20-16PL/Li-Ion

RX 20-18P/Li-Ion

RX 20-18PL/Li-Ion

RX 20-20P/Li-Ion

RX 20-20PL/Li-Ion



first in intralogistics

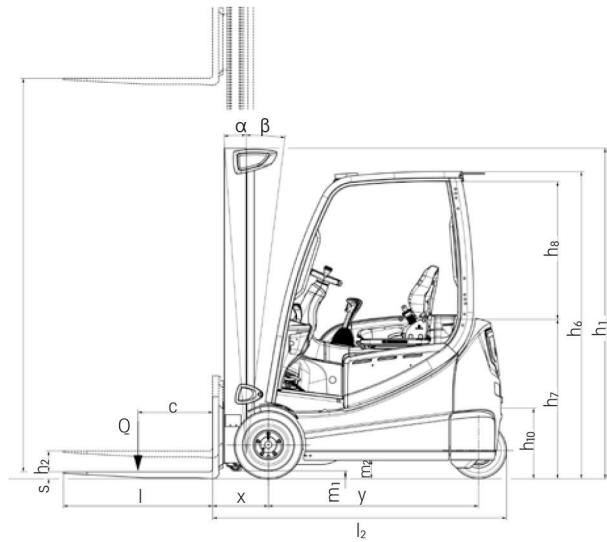

3-wheel side view

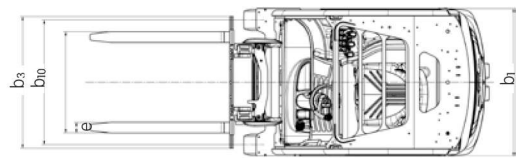

3-wheel top view

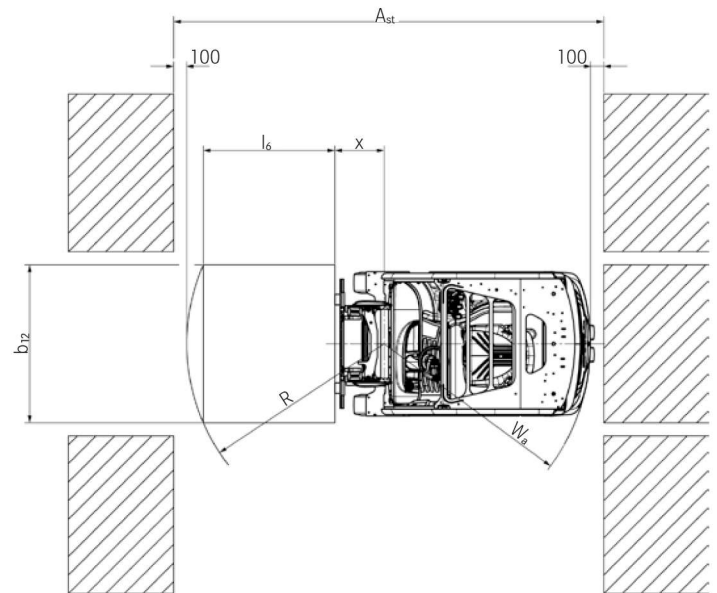

3-wheel top view

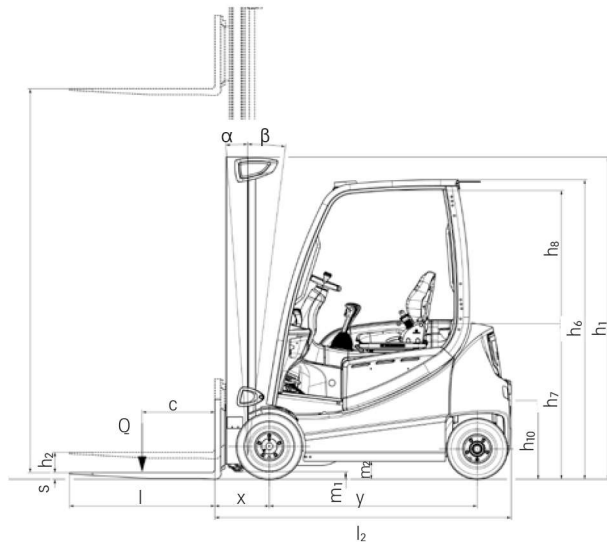

4-wheel side view

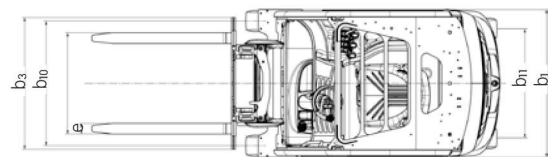

4-wheel top view

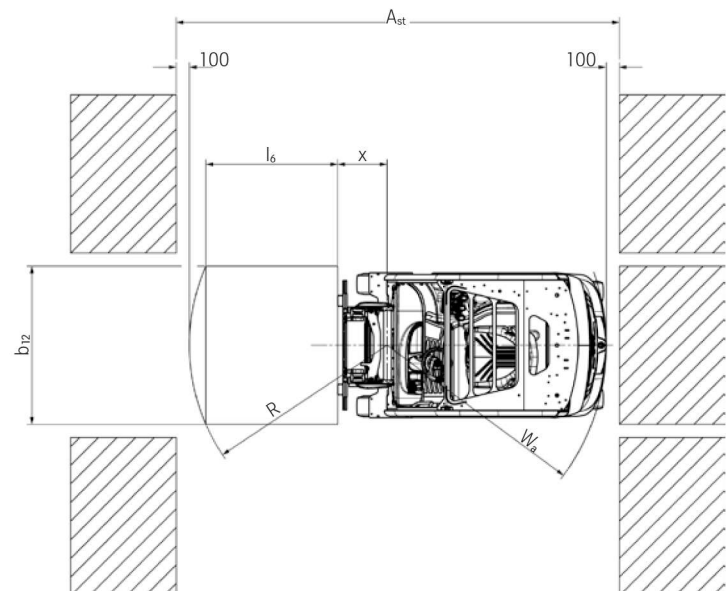

4-wheel top view



RX 20-14C Duplex/NiHo mast single SE tyres

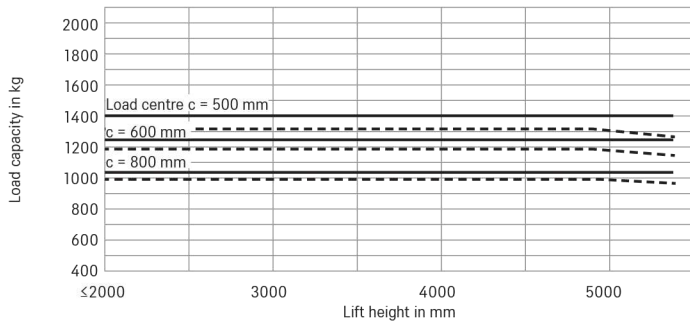

RX 20-14C Triplex mast single SE tyres

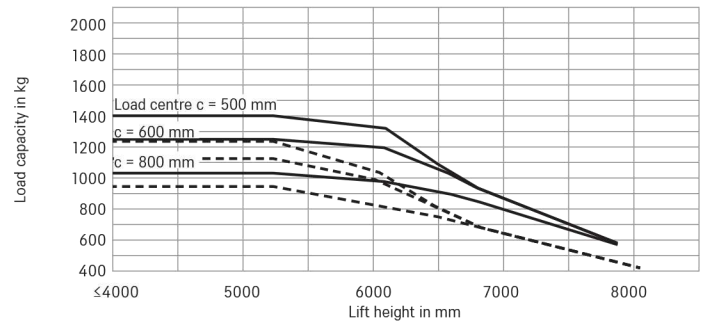

RX 20-16C Duplex/NiHo mast single SE tyres

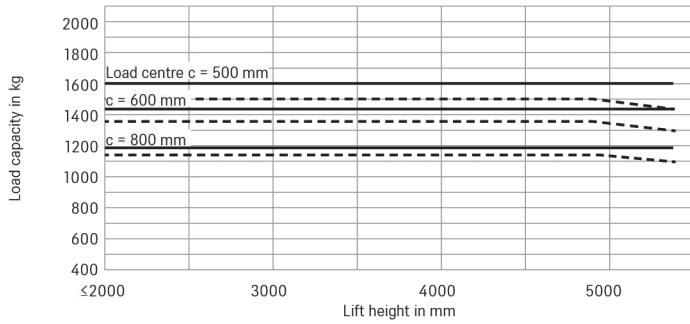

RX 20-16C Triplex mast single SE tyres

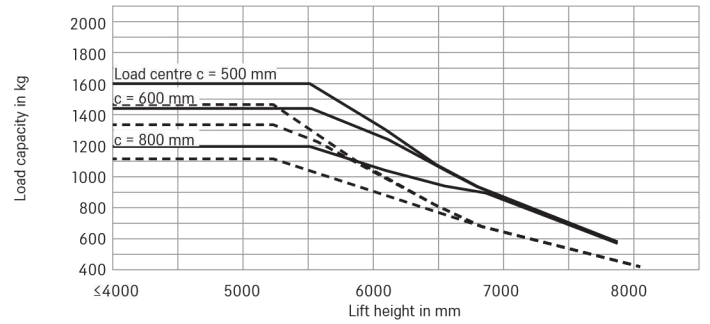

RX 20-16/RX 20-16P Duplex/NiHo mast single SE tyres

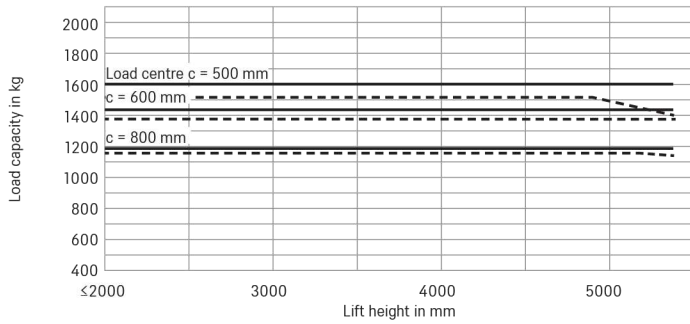

RX 20-16/RX 20-16P Triplex mast single SE tyres

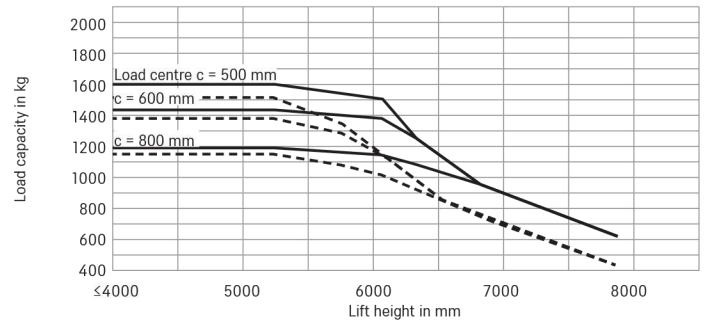

RX 20-16L/RX 20-16PL Duplex/NiHo mast single SE tyres

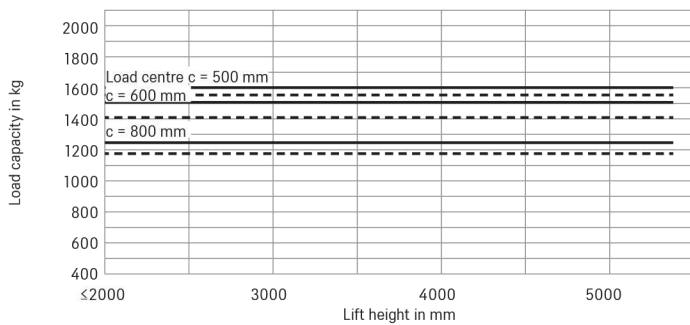

RX 20-16L/RX 20-16PL Triplex mast single SE tyres

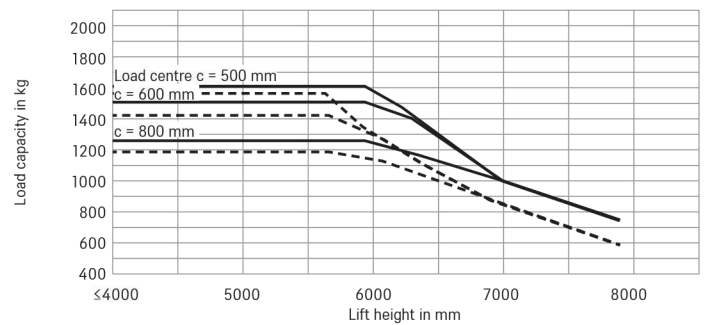

———— with standard forks - - - - - with integrated side shifter and standard forks
The listed values may vary depending on the forklift equipment

RX 20-18/RX 20-18P Duplex/NiHo mast single SE tyres

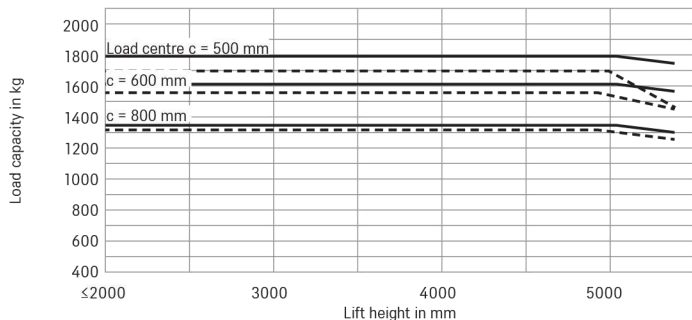

RX 20-18/RX 20-18P Triplex mast single SE tyres

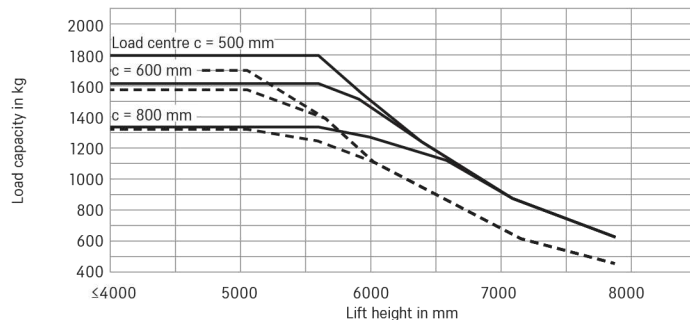

RX 20-18L Duplex/NiHo mast single SE tyres

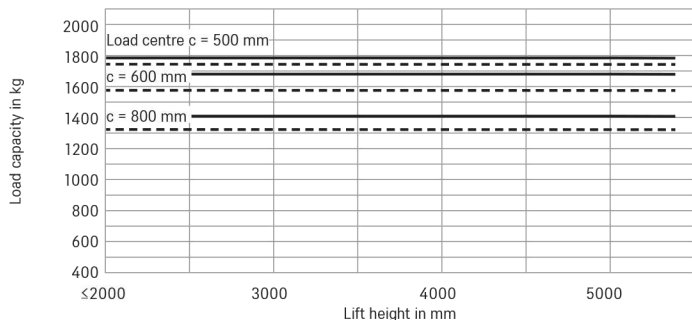

RX 20-18L Triplex mast single SE tyres

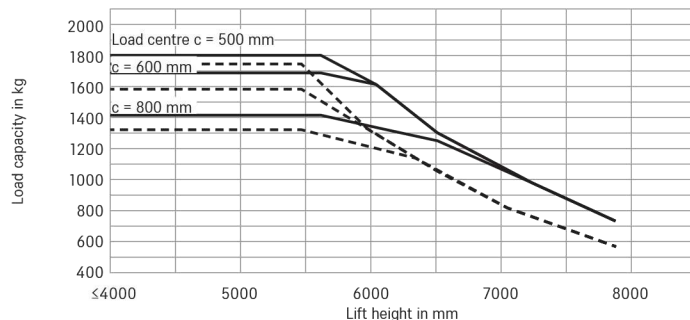

RX 20-18PL Duplex/NiHo mast single SE tyres

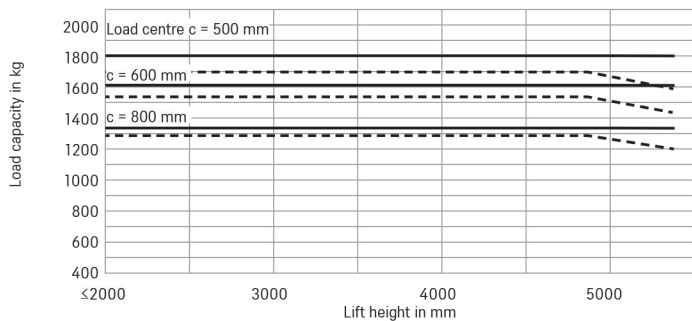

RX 20-18PL Triplex mast single SE tyres

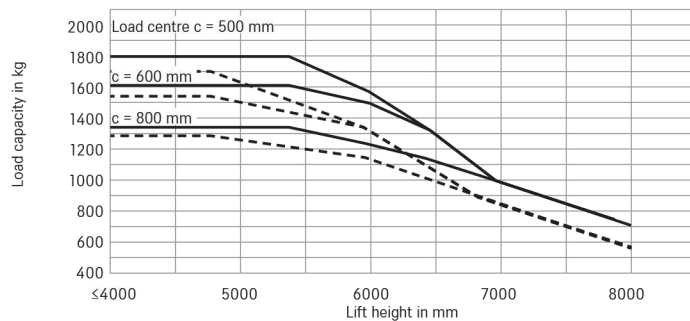

RX 20-20P Duplex/NiHo mast single SE tyres

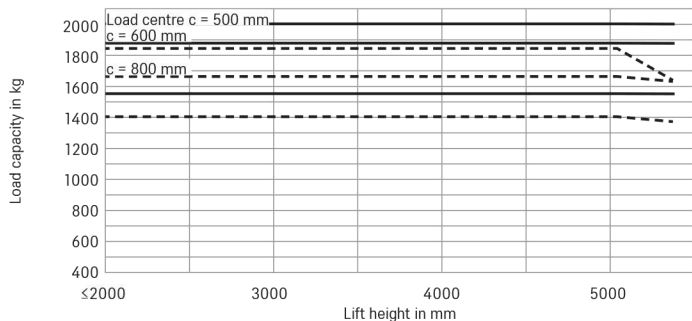

RX 20-20P Triplex mast single SE tyres

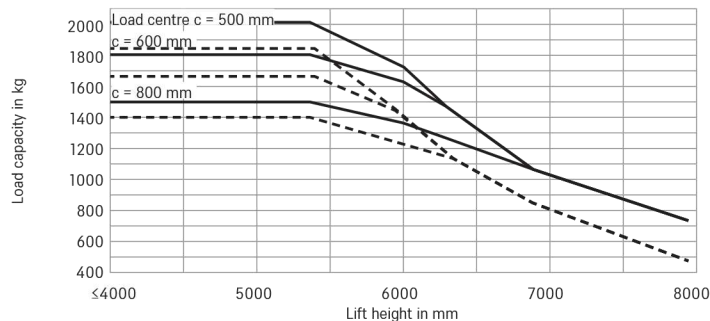

RX 20-20L/RX 20-20PL Duplex/NiHo mast single SE tyres

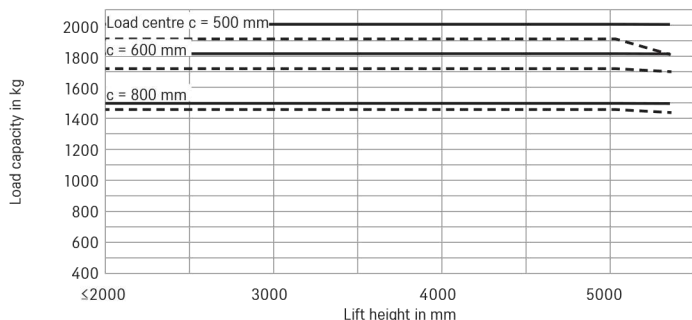

RX 20-20L/RX 20-20PL Triplex mast single SE tyres

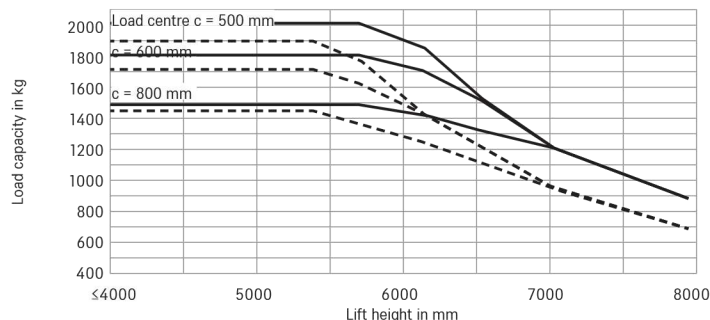

———— with standard forks - - - - - with integrated side shifter and standard forks
The listed values may vary depending on the forklift equipment



Four-wheel version with fully enclosed driver's cabin for outdoor use



Optimal view of fork tips when loading HGVs

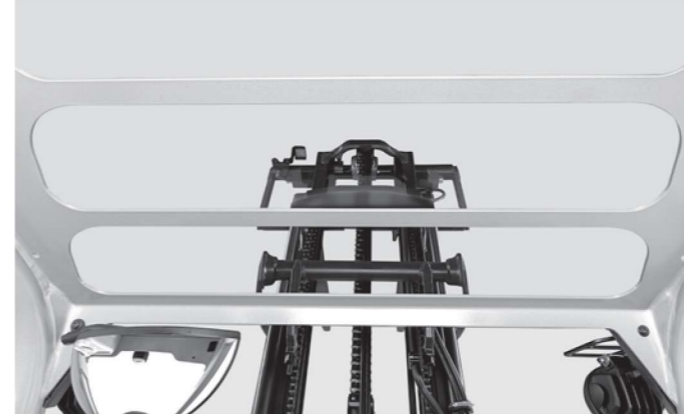

View upwards



Enhanced visibility thanks to panoramic armoured glass pane



Spacious access and footwell



Optional onboard charger for decentralized charging without battery change



Workspace with display and control units, Joystick 4Plus and heating



Work fast and safely thanks to excellent visibility over and past the Easy View mast



Wide seat with fabric cover and right armrest



Swivel seat handle with optional horn operation for ergonomic reverse driving



Swivel seat for comfortable reversing



Battery change with electric pallet truck

Gradients

With nominal load	Gradient	Maximum distance in m													
		RX 20-14C	RX 20-16C	RX 20-16	RX 20-16L	RX 20-16P	RX 20-16PL	RX 20-18	RX 20-18L	RX 20-18P	RX 20-18PL	RX 20-20L	RX 20-20P	RX 20-20PL	
	22.9%	1860	1501	1502	1501	1517	1509	1423	1431	1431	1439	1079	1054	1079	
	18.6%	3350	3380	3458	3456	3559	3442	3284	3300	3300	3300	2611	2546	2611	
	1.2%	7770	7531	7663	7489	7741	7533	7322	7346	7269	7582	6857	6870	6883	
	6.1%	14683	13751	13761	13450	14070	13637	13320	13318	13164	13320	12186	12187	12500	
Without load	25.1%	3421	3221	3285	3213	3325	3213	3151	3134	3137	3215	3027	3196	3027	
	18.1%	8230	8037	8165	7884	8244	8017	7876	7762	7768	7949	5632	5610	5642	
	9.6%	15316	14432	15066	14402	14937	14402	13969	13958	13969	14183	13570	13483	13601	
	4.7%	20000	20000	20000	20000	20000	20000	20000	20000	20000	20000	20000	20000	20000	

Maximum distance that can be driven in 60 minutes.
Example: With a load of 1,800 kg and a gradient of 18.6%, an RX 20-18P can drive a distance of 330 m up to ten times in an hour.

Dry rough concrete = coefficient of friction 0.80
Battery: standard as per data sheet; speed is variable

Highest handling performance of its class

Highest range with one battery charge

Best all-round visibility for high work safety

High agility and precise manoeuvrability



The STILL RX 20 offers more of everything: more power, more dynamism and more availability. The latest generation of STILL's top-selling electric forklift truck is the best RX 20 that STILL ever developed. There is the new safety and communication centre for safety and handling performance (STILL Easy Control): The driver can activate performance functions depending on the application and receives all important safety information at a glance. With the safest and quickest battery change and the largest Li-Ion battery capacity of its class, the RX 20 can be used around the clock. Dynamic acceleration, 20 km/h maximum speed, precise manoeuvrability – with these trademark features, the RX 20 achieves the highest ever handling performance in the load range from 1.4 to 2 tonnes.

When it comes to narrow aisle widths in heavy-duty two- or three-shift applications, the RX 20 really shows its strengths. This includes beverages and hardware stores, the receipt and dispatch of goods in trade and logistics applications, or production supply in the mechanical engineering and automotive industries. Equipped with Li-Ion technology, the RX 20 Li-Ion is number one for availability. Just 30 minutes of charging extend the usage time by several operating hours. The compact electric forklift truck gets its energy from Li-Ion batteries which are suitable for cold storage. When in operation, an intelligent electronics system monitors every battery cell in real time. Safety, performance and availability are what make the RX 20 Li-Ion a uniquely efficient conveyor of goods.

The 'Simply Efficient' factors: Performance attributes as a measure of economic efficiency

Simply easy

- Intuitive handling: standard, easy-to-use operating concept across the whole RX product line
- Efficiency-enhancing: easy entry into a highly ergonomic driver's cab
- STILL Easy Control on-board computer: all relevant information at a glance and performance functions just a click away
- Ultra-fast: easy-to-operate lateral battery change

- Systematic safety: optional pre-shift check on the display to help with the daily safety inspection
- Safety for every application: wide range of additional equipment options – from a direction indicator on the display to the Safety Light 4Plus safety lighting, as well Curve Speed Control for automatic speed reduction when cornering

Simply powerful

- Intralogistics powerhouse: highest handling performance of its class
- Performance boost: sprint mode for peak performance at the touch of a button
- Optimum energy efficiency: exceptionally long range with each battery charge
- Intelligent support: traction control and other assistance functions
- Ready at all times: optional STILL lithium-ion technology for maximum availability

Simply flexible

- Customised control options: multi-lever, mini-lever, Fingertip or Joystick 4Plus
- Adjustable performance dynamics: parameters such as driving and lifting speed can be adjusted to personal preferences at the touch of a button
- Operating power tailored to your specifications: wide variety of equipment options for every application
- Flexible, decentralised charging: Onboard Charger enables simple, fast and location-independent charging processes

Simply safe

- Safe and precise handling: high-precision hydraulics and agile driving dynamics
- Safe entry: large handle, anti-slip rubber mat and wide step
- Optimal panoramic view: slim mast and extra-large windows

Simply connected

- Optimum networking: optional interface for integration into fleet management software such as STILL neXXt fleet
- Controlled use: optional access control protects against incorrect operation



	RX 20-14C RX 20-16C	RX 20-16 RX 20-18	RX 20-16L RX 20-18L RX 20-20L	RX 20-16P RX 20-18P RX 20-20P	RX 20-16PL RX 20-18PL RX 20-20PL
Driver's cab	Weather-protected, canvas or full cab	○	○	○	○
	Drive-in overhead guard with Makrolon roof	○	○	○	○
	Overhead guard height 1949 mm for low passages	○	○	○	○
	Window made of either green-tinted or Makrolon laminated safety glass	○	○	○	○
	Pad with clipboard (removable)	○	○	○	○
	MSG 65 Grammer seat with leatherette upholstery	●	●	●	●
	Seat with fabric cover, air suspension, leatherette upholstery, lumbar support, height-adjustable backrest	○	○	○	○
	Seat heating	○	○	○	○
	Swivel seat can be rotated to the right	○	○	○	○
	Handle on the front and back of the overhead guard	●	●	●	●
	Horizontal spring plate for driver's seat to minimise human vibrations	○	○	○	○
	Roof liner with interior lighting	○	○	○	○
	DAB+ radio/MP3 player with USB connection/Bluetooth and hands-free kit	○	○	○	○
	Electrical heating 2000 W incl. defrosting blaster	○	○	○	○
	Clamp mount for mobile phone, mounted adjustably on the overhead guard bar	○	○	○	○
	Mast	Colour display and intuitive menu navigation	●	●	●
Panoramic armoured glass pane		○	○	○	○
Adjustable roof window		○	○	○	○
Raised driver's workplace (208 mm) for optimal view over bulky loads, e.g. beverage industry		○	○	○	○
Storage box above the counterweight		○	○	○	○
Easy View central mast		○	○	○	○
Load backrest		○	○	○	○
Mast vertical position		○	○	○	○
Bellows protect the tilt cylinder from dust and moisture		○	○	○	○
Fork wear protection		○	○	○	○
Hydraulics	Various fork carriage widths, integrated sideshifting and fork adjusting devices	○	○	○	○
	Display showing tilt angle and cushioned lowering in the tilt end positions	○	○	○	○
	Proportional valve technology for especially sensitive movements	○	○	○	○
	Multi-lever operation	●	●	●	●
Drives	Armrest with mini-levers, Fingertip or Joystick 4Plus	○	○	○	○
	Hydraulic vibrating function facilitates the emptying of container	○	○	○	○
	Cold store version with special low temperature oil	○	○	○	○
	Low operating costs due to low energy consumption	●	●	●	●
	3 pre-set and 2 freely configurable driving modes	●	●	●	●
	Blue-Q energy-saving mode	●	●	●	●
	Display showing energy consumption and remaining driving time based on current charge	●	●	●	●
	Maintenance-free drives for driving, steering and lifting	●	●	●	●
	Enclosed components to protect against dust and damp	●	●	●	●
	Operating hours counter only operational with drive and lifting motor	●	●	●	●
	Li-Ion battery exchangeable 1:1	○	○	○	○
	Hydraulic battery replacement system for convenient changing using a crane	—	○	○	○
Option to switch from battery circuit A to battery circuit B	—	○	—	—	
Sprint mode for highest handling performance at the push of a button	●	●	●	●	
On-board charger	—	○	○	○	
Fast-charging access	○	○	○	○	
Brake	Wear-free disc brakes that run in an oil bath	●	●	●	●
	Energy recovery when braking	●	●	●	●
	Mechanical parking brake	●	●	●	●
	Electromechanical parking brake	○	○	○	○
Safety	EasyBelt restraint system for quick and safe fastening and unfastening	○	○	○	○
	Sauerermann type HRS-E/ERS duo restraint system or IWS restraint system with strap opening on the left	○	○	○	○
	Headlights and LED lighting performance	○	○	○	○
	LED floodlight on the mast	○	○	○	○
	Driver-adjusted speed limiter	○	○	○	○
	STILL Safety Light 4Plus warning device	○	○	○	○
	Safety Zone Light: warning light bars on the left and right of the vehicle	○	○	○	○
	Curve Speed Control	●	●	●	●
	Speed limitation when fork carriage is raised	○	○	○	○
	Load measuring	○	○	○	○
	Panoramic mirror	○	○	○	○
	Roof sensor for indoor and outdoor speed control	○	○	○	○
	Direction can be changed both left- and right-handed via mini-console	○	○	○	○
	FleetManager: access rights, shock detection, reports	○	○	○	○
	Overload protection	○	○	○	○
	Lifting height sensor for exact measurement of the lifting height with optional assistance functions	○	○	○	○
Pre-shift check on the display for a guided safety check before starting to drive	○	○	○	○	
Intelligent seat belt control	●	●	●	●	
Stability assistance system Dynamic Load Control	○	○	○	○	
Surround View: 360° camera view	○	○	○	○	
Explosion-proof version	○	○	○	○	
Pre-fitting for public road traffic	○	○	○	○	

STILL GmbH
Berzeliusstr. 10
22113 Hamburg
Germany
Tel.: +49 40 73 39 20 00
Fax: +49 40 73 39 20 01
info@still.de

For further information please visit
www.still.eu



Gemini Equipment And Rentals Pvt. Ltd.
1706-1709, The Corporate Park 17th Floor Plot No-14-15
Vashi Navi Mumbai -400705, India.
Email id : info@gear-india.com | Contact No: +918451934343 |
Website: www.gear-india.com

STILL is certified in the following areas: Quality management, occupational safety, environmental protection and energy management.

