

HELI

GEAR
Keeps you going

CBD35-510/520/530 Electric Pallet Truck

NEW



Configuration and performance

- Electronic power steering system, light and low noise.
- Drive unit floating bodies with patent design.
- AC Driving system, No carbon brush, maintenance free.
- Electromagnetic, regenerative braking system.
- Automatic lifting limit, Motor and battery life extension.
- Load backrest is standard.
- Side-way battery is standard.
- Options: Long or short forks.

Safety

- Curve automatic deceleration devices, more safe.
- Stepless speed control system, safe and quiet.
- Controller with multiple automatic protection.
- Emergency reversing device/Emergency brake switch.

Options

- Battery: FAAM 330/490Ah.

EPS | AC | 14km/h

Double pallets, high efficiency

Feature		CBD35	CBD35	CBD35
Model		CBD35	CBD35	CBD35
Configuration No.		510	520	530
Loading capacity	kg	3500	3500	3500
Apply to pallet		Double pallet	Single pallet	Single pallet
Wheel base	mm	2084	1602	1602
Operating type		Rider	Rider	Walkie
Wheels				
Wheels type		PU	PU	PU
Wheel quantity Driving wheel/Balance wheel/Bearing wheel		1/4/2	1/4/2	1/4/2
Driving wheel size	mm	∅ 300×120	∅ 300×120	∅ 300×120
Bearing wheel size	mm		∅ 84×152	
Balance wheel size	mm	∅ 115×55	∅ 115×55	∅ 115×55
Dimension				
Min.fork lowered height	mm	85	85	85
Max.fork lifting height	mm	230	230	230
Max.lifting height	mm	145	145	145
Overall fork width (Outside/Inside)	mm	680/180	680/220	680/220
Fork length	mm	2432	1212/1365/1517	1212/1365/1517
Fork width	mm	250	230	230
Fork thickness	mm	60	60	60
Overall length	mm	3605	2374	2222
Overall width	mm	930	930	832
Overall height(With handle)	mm	1536	1536	1536
Overall height(Without handle)	mm	1280	1280	1280
Min.Turning radius	mm	2708	2190	2051
Min.Aisle width for pallets 1200×1200	mm	3650	2536	2365
Performance				
Travel speed,laden/unladen	km/h	11/14	11/14	4/4.5
Lift speed,laden/unladen	mm/s	35/40	35/40	35/40
Lowering speed,laden/unladen	mm/s	35/30	35/30	35/30
Gradeability,laden/unladen	%	5/12	5/12	5/10
Electrical configuration				
Drive motor	kW	AC 4.2	AC 4.2	AC 1.5
Lift motor	kW	DC 2.2	DC 2.2	DC 2.2
Steering motor	kW	DC 0.15	DC 0.15	DC 0.15
Battery voltage / capacity	V/Ah	24/360	24/360	24/360
Brake		Electromagnetic/Regenerative	Electromagnetic/Regenerative	Electromagnetic/Regenerative
Controller		ZAPI	ZAPI	ZAPI
Weight				
Battery weight	kg	302	302	302
Service weight with battery	kg	1146	1038	910

* Details of specifications and equipment are based on information available at time of printing and may change without notice.

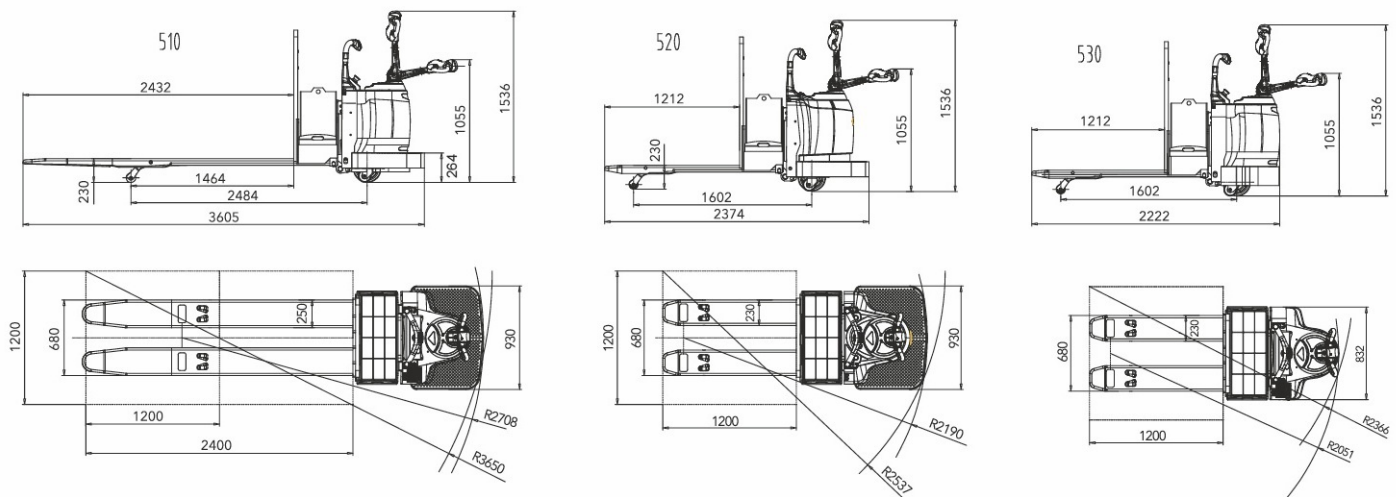

Gemini Equipment And Rentals Pvt. Ltd.

1706-1709, The Corporate Park 17th Floor Plot No-14-15

Vashi Navi Mumbai -400705, India.

Email id : info@gear-india.com | Contact No: +918451934343 |

Website: www.gear-india.com