

EK-X Technical Data Vertical Order Picker

EK-X 10

EK-X/Li-Ion



EK-X 10 Vertical Order Picker

The new dimension in order picking

This specification sheet to VDI guideline 2198 only gives the technical figures for selected equipment variants.



	1.1	Manufacturer		STILL	STILL	STILL			
Distinguishing marks	1.2	Manufacturer's type designation		EK-X 10 single mast without additional lift	EK-X 10 single mast with additional lift	EK-X 10 telescopic mast with additional lift			
	1.3	Drive		Electric 24 V	Electric 24 V	Electric 24 V			
	1.4	Operator type		Standing/order-picker	Standing/order-picker	Standing/order-picker			
	1.5	Rated capacity/rated load	Q	kg	1000	1000	1000		
	1.6	Load centre distance	c	mm	400	400	400		
	1.8	Load distance, centre of drive axle to fork	x	mm	180	180	180		
	1.9	Wheel base	y	mm	1270	1260	1415		
	Weights	2.1	Service weight (incl. battery)		kg	1564	2069	2711	
		2.2	Axle loading, laden	drive end/load end		kg	536/2028	688/2381	1050/2661
2.3		Axle loading, unladen	drive end/load end		kg	1006/558	1168/901	1479/1232	
Tyres/chassis	3.1	Tyres			Polyurethane	Polyurethane	Polyurethane		
	3.2	Tyre size	drive end		mm	Ø 250 x 100	Ø 250 x 100	Ø 250 x 100	
	3.3	Tyre size	load end		mm	Ø 125 x 105	Ø 125 x 105	Ø 150 x 100	
	3.5	Wheels, number (x = driven wheels)	drive end/load end			1x/2	1x/2	1x/2	
	3.7	Tread	load end		b ₁₁	mm	660	850	850
Dimensions	4.2	Height	mast lowered		h ₁	mm	1620	2530	2900
	4.4	Lift			h ₃	mm	1000	1910	4550
	4.5	Height	mast extended		h ₄	mm	2395	4170	6810
	4.7	Height of overhead guard (cabin)			h ₆	mm	-	2260	2260
	4.8	Stand height	lowered		h ₇	mm	200	200	200
	4.11	Additional lift			h ₉	mm	-	800	800
	4.14	Stand height	elevated		h ₁₂	mm	1200	2110	4750
	4.14.1	Order picking height (h ₁₂ + 1600 mm)	elevated		h ₂₈	mm	2800	3710	6350
	4.15	Height	lowered		h ₁₃	mm	65	65	65
	4.19	Overall length			l ₁	mm	2465	2475	2630
	4.20	Length to face of forks			l ₂	mm	1665	1675	1830
	4.21	Overall width			b ₁ /b ₂	mm	790/790	980/980	980/980
	4.22	Fork dimensions			s/e/l	mm	60/120/800	60/120/800	60/120/800
	4.23	Fork carriage ISO 2328, class/type A, B					Welded forks	Welded forks	Welded forks
	4.24	Fork-carriage width			b ₃	mm	-	740	740
	4.25	Distance between fork-arms	min./max.		b ₅	mm	560	640	640
	4.27	Width across guide rolls			b ₆	mm	-	1375	1375
	4.31	Ground clearance, laden, below mast			m ₁	mm	40	40	38
	4.32	Ground clearance, centre of wheelbase			m ₂	mm	40	40	38
	4.34.1	Aisle width for pallets 1200 x 800 lengthwise			A _{st}	mm	3122	-	-
	4.34.2	Aisle width for pallets 1200 x 800 crosswise			A _{st}	mm	2834	1380	1380
4.35	Turning radius			W _a	mm	1485	1495	1650	
4.42	Transfere aisle with, minimum			A _u	mm	2834	2844	2999	
4.44	Clear width, driver compartment entry				mm	460	460	460	
4.45	Clear driver compartment height inside				mm	-	2000	2000	
Performance data	5.1	Travel speed	laden/unladen		km/h	9.0/9.0	10.0/10.0	10.0/10.0	
	5.2	Lift speed	laden/unladen		m/s	0.15/0.19	0.18/0.25	0.22/0.31	
	5.3	Lowering speed	laden/unladen		m/s	0.30/0.24	0.30/0.24	0.30/0.24	
	5.9	Acceleration time (over 10 m)	laden/unladen		s	7/7	7/7	7/7	
	5.10	Service brake				Regenerative	Regenerative	Regenerative	
Electric engine	6.1	Drive motor rating S2 60 min			kW	3.0	3.0	3.0	
	6.2	Lift motor rating at S3 15%			kW	3.2 ¹	4.0	7.6	
	6.3	Battery according to DIN 43535				3PzS 420/B	4PzS 560/B	4PzS 560/B	
	6.4	Battery voltage/nominal capacity K _s			V/Ah	24/420	24/560	24/560	
	6.5	Battery weight (dependent on manufacturer ±5%)			kg	385	502	502	
Misc.	10.7	Sound level at the driver's seat			dB(A)	61	63	69	
		With our VNAP tool we will calculate the technical specifications of the truck with your individual equipment. The calculated speed profiles are based on our floor quality rules. Subject to change without notice. Values can vary ±10%.							

¹ S3 = 10%

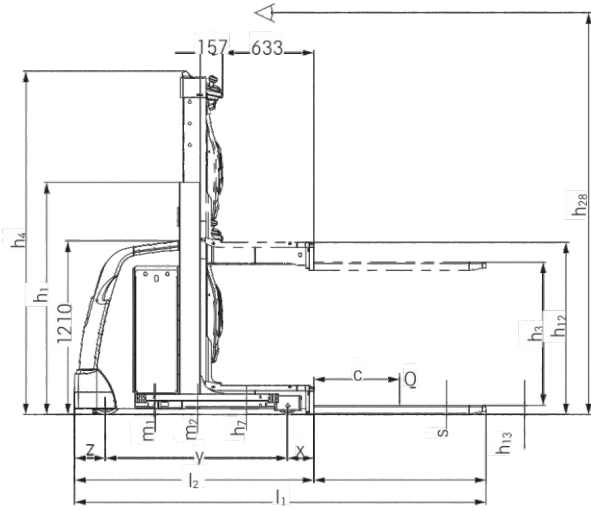

Side view EK-X 10 single mast without auxiliary lift

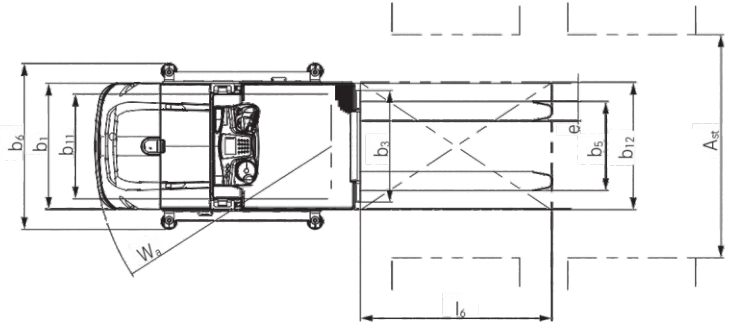

Top view EK-X 10 single mast without auxiliary lift

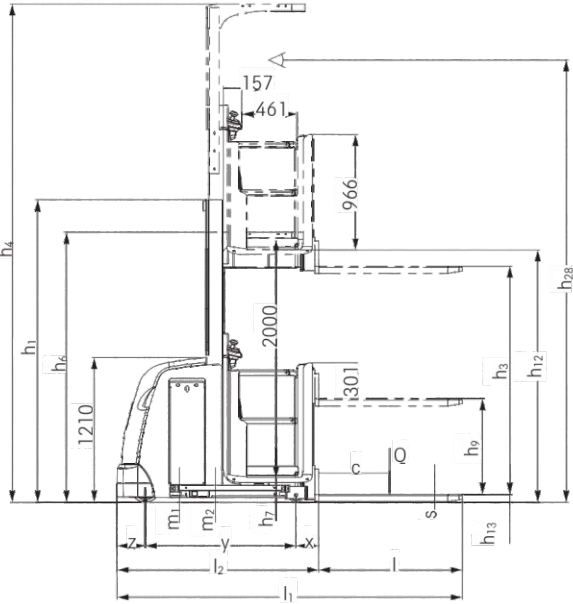

Side view EK-X 10 single mast with auxiliary lift

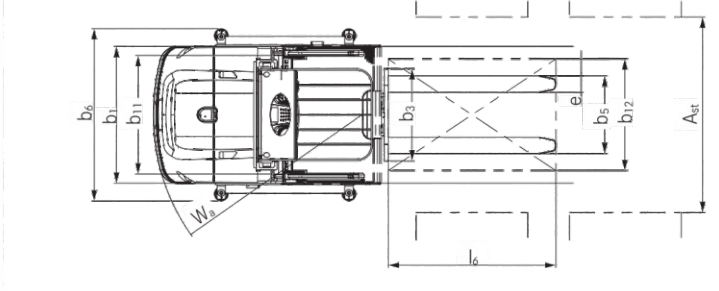

Top view EK-X 10 single mast with auxiliary lift

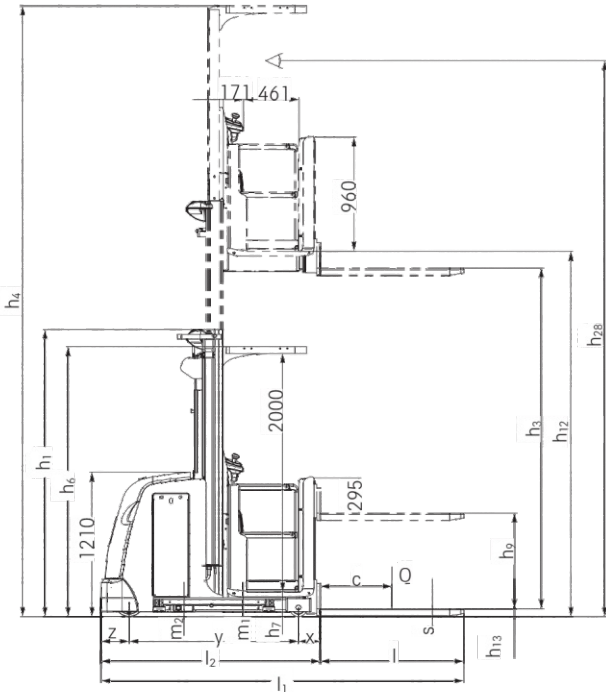

Side view EK-X 10 telescopic mast with auxiliary lift

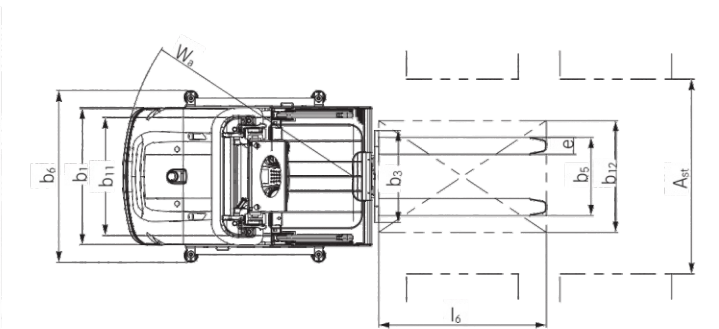

Top view EK-X 10 telescopic lift mast with auxiliary lift



Distinguishing marks		Manufacturer	STILL	STILL	STILL	STILL	STILL	STILL
1.1	Manufacturer		STILL	STILL	STILL	STILL	STILL	STILL
1.2	Manufacturer's type designation		EK-X up to 1000 kg	EK-X up to 1000 kg	EK-X telescopic mast	EK-X triplex mast	EK-X/Li-Ion telescopic mast	EK-X/Li-Ion triplex mast
1.3	Drive		Electric 24 V	Electric 48 V	Electric 24 V	Electric 24 V	Electric 48 V	Electric 48 V
1.4	Operator type		Standing/order-picker	Standing/order-picker	Standing/order-picker	Standing/order-picker	Standing/order-picker	Standing/order-picker
1.5	Rated capacity/rated load	Q	kg 1000	1000	1000	1000	1200	1200
1.6	Load centre distance	c	mm 600	600	400	400	400	400
1.8	Load distance, centre of drive axle to fork	x	mm 405	405	345	405	345	405
1.9	Wheel base	y	mm 1415	1448	1487	1595	1520	1628
Weights								
2.1	Service weight (incl. battery)		kg 3168	3227	2887	3688	2948	3747
2.2	Axle loading, laden	drive end/load end	kg 955/3213	999/3228	1094/2793	1502/3186	1027/3121	1427/3520
2.3	Axle loading, unladen	drive end/load end	kg 1709/1459	1736/1491	1636/1250	2062/1627	1664/1283	2085/1662
Tyres/chassis								
3.1	Tyres		Polyurethane	Polyurethane	Polyurethane	Polyurethane	Polyurethane	Polyurethane
3.2	Tyre size	drive end	mm 360/130	360/130	∅ 360 x 130	∅ 360 x 130	∅ 360 x 130	∅ 360 x 130
3.3	Tyre size	load end	mm 180/156	180/156	∅ 180 x 156	∅ 180 x 156	∅ 180 x 156	∅ 180 x 156
3.5	Wheels, number (x = driven wheels)	drive end/load end	1x/2	1x/2	1x/2	1x/2	1x/2	1x/2
3.7	Tread	load end	b ₁₁ mm 1000	1000	700	1000	700	1000
4.2	Height	mast lowered	h ₁ mm 3400	3400	2250	2250	2250	2250
4.3	Free lift		h ₂ mm -	-	-	1600	-	1600
4.4	Lift		h ₃ mm 5000	5000	2825	4410	2825	4410
4.5	Height	mast extended	h ₄ mm 7484	7484	5315	6900	5315	6900
4.7	Height of overhead guard (cabin)		h ₆ mm 2484	2484	2490	2490	2490	2490
4.8	Stand height		h ₇ mm 233	233	240	240	240	240
4.11	Additional lift		h ₉ mm 800	800	740	740	740	740
4.14	Stand height	elevated	h ₁₂ mm 5233	5233	3065	4650	3065	4650
4.14.1	Order picking height (h ₁₂ + 1600 mm)	elevated	h ₂₈ mm 6833	6833	4665	6250	4665	6250
4.15	Height	lowered	h ₁₃ mm 45	45	65	65	65	65
4.19	Overall length		l ₁ mm 3215	3248	3277	3126	3310	3159
4.20	Length to face of forks		l ₂ mm 2065	2098	2077	2326	2110	2359
4.21	Overall width		b ₁ /b ₂ mm 1180/1180	1180/1180	880/880	1180/1180	880/880	1180/1180
4.22	Fork dimensions		s/e/l mm 40/120/1150	40/120/1150	55/120/1200	55/120/800	55/120/1200	55/120/800
4.23	Fork carriage ISO 2328, class/type A, B		ISO l special fork carriage	ISO l special fork carriage	Welded forks	Welded forks	Welded forks	Welded forks
4.24	Fork-carriage width		b ₃ mm 640	640	660	740	660	740
4.25	Distance between fork-arms		b ₅ mm 420/640	420/640	560	640	560	640
4.27	Width across guide rolls		b ₆ mm Inductive	Inductive	1155	1375	1155	1375
4.31	Ground clearance, laden, below mast		m ₁ mm 50	50	50	50	50	50
4.32	Ground clearance, centre of wheelbase		m ₂ mm 50	50	50	50	50	50
4.34.1	Aisle width for pallets 1200 x 800 lengthwise		A _{st} mm 1480	1480	1160	-	1160	-
4.34.2	Aisle width for pallets 1200 x 800 crosswise		A _{st} mm 1480	1480	-	1380	-	1380
4.35	Turning radius		W _a mm 1660	1693	1732	2040	1765	2071
4.42	Transfere aisle with, minimum		A _u mm 4073	4106	3528	3586	3561	3617
4.44	Clear width driver compartment entrance		mm 460	460	640	640	640	640
4.45	Clear driver compartment height inside		mm 2000	2000	2200	2200	2200	2200
Performance data								
5.1	Travel speed	laden/unladen	km/h 9.0/9.0	9.0/9.0	10.0/10.0	10.0/10.0	11.0/11.0	13.0/13.0
5.2	Lift speed	laden/unladen	m/s 0.25/0.30	0.40/0.40	0.23/0.30	0.20/0.30	0.32/0.40	0.36/0.40
5.3	Lowering speed	laden/unladen	m/s 0.28/0.28	0.35/0.35	0.28/0.28	0.28/0.28	0.35/0.35	0.35/0.35
5.9	Acceleration time (over 10 m)	laden/unladen	s 8/8	7/7	7/7	7/7	6/6	6/6
5.10	Service brake		Regenerative	Regenerative	Regenerative	Regenerative	Regenerative	Regenerative
Electric engine								
6.1	Drive motor rating S2 60 min		kW 4.0	6.5	4.0	4.0	6.5	6.5
6.2	Lift motor rating at S3 15%		kW 7.6	13.0/S3 = 20%	7.6	7.6	13	13
6.3	Battery according to DIN		43535 A	43531 A	43535 A	43535 A	43531 A	43531 A
6.4	Battery voltage/nominal capacity K _s		V/Ah 24/1120	48/620	24/840	24/1120	48/420 Li-Ion 48/813	48/560 Li-Ion 48/813
6.5	Battery weight (dependent on manufacturer ±5%)		kg 883	933	687	883	739	933
10.7	Sound level at the driver's seat		dB(A) 64	64	61	61	61	61
Misc.		With our VNAP tool we will calculate the technical specifications of the truck with your individual equipment. The calculated speed profiles are based on our floor quality rules. Subject to change without notice. Values can vary ±10%.						

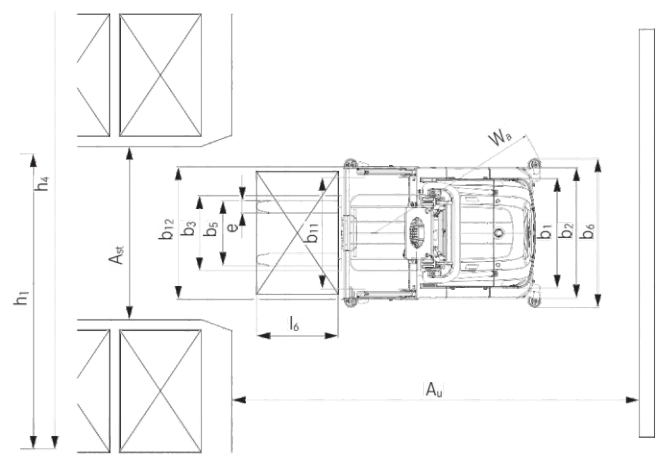

Side view EK-X with telescopic mast and additional lift up to 1000 kg

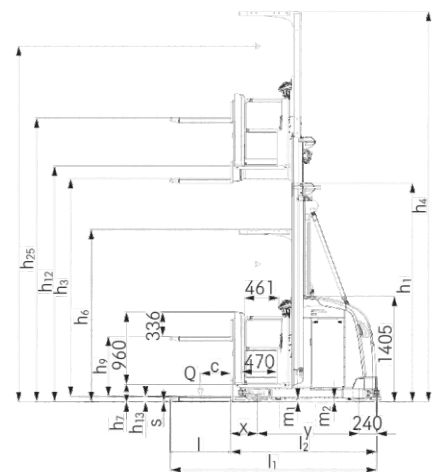

Top view EK-X with telescopic mast and additional lift up to 1000 kg

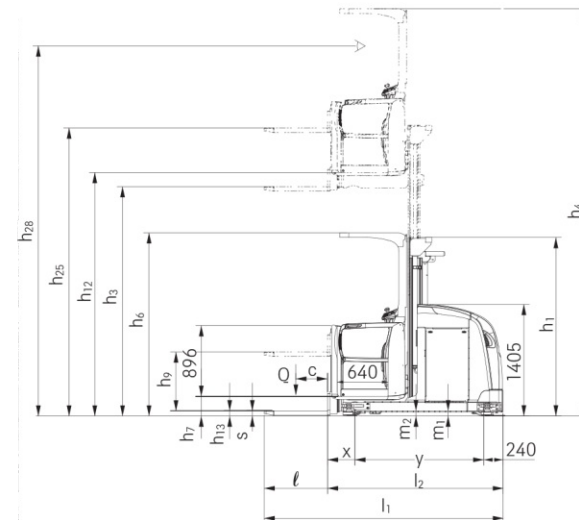

Side view EK-X with telescopic mast and additional lift up to 1200 kg

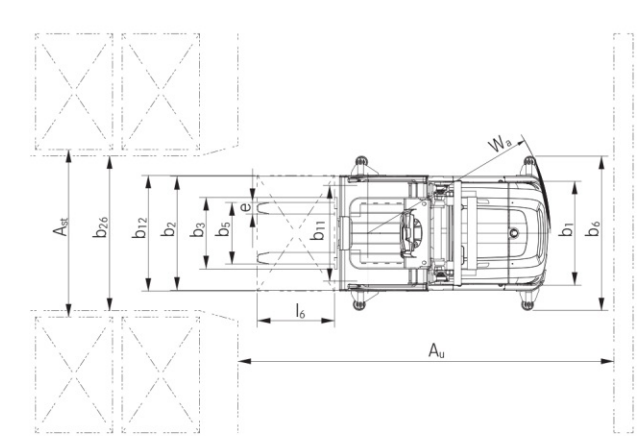

Top view EK-X with telescopic mast and additional lift up to 1200 kg

EK-X Vertical Order Picker Mast Tables



EK-X 10 single mast with additional lift	Height, mast lowered	h_1	mm	1620	2120	2530
	Total lift above floor ²	$h_{25} (h_3 + h_9 + h_{13})$	mm	1865	2365	2775
	Total lift ²	$h_{24} (h_3 + h_9)$	mm	1800	2300	2710
	Nominal lift	h_3	mm	1000	1500	1910
	Height, lowered	h_{13}	mm	65	65	65
	Additional lift ²	h_9	mm	800	800	800
	Stand height, elevated	$h_{12} (h_3 + h_7)$	mm	1200	1700	2110
	Picking height	$h_{28} (h_{12} + 1,600)$	mm	2800	3300	3710
	Height, mast extended ¹	h_4	mm	2395	3760	4170

EK-X 10 telescopic mast with additional lift	Height, mast lowered	h_1	mm	2400	2900
	Total lift above floor ²	$h_{25} (h_3 + h_9 + h_{13})$	mm	4415	5415
	Total lift ²	$h_{24} (h_3 + h_9)$	mm	4350	5350
	Nominal lift	h_3	mm	3550	4550
	Height, lowered	h_{13}	mm	65	65
	Additional lift ²	h_9	mm	800	800
	Stand height, elevated	$h_{12} (h_3 + h_7)$	mm	3750	4750
	Picking height	$h_{28} (h_{12} + 1,600)$	mm	5350	6350
	Height, mast extended ¹	h_4	mm	5810	6810

EK-X telescopic mast up to 1000 kg	Height, mast lowered	h_1	mm	2,250	2400	2900	3400	3900
	Total lift above floor	$h_{25} (h_3 + h_9 + h_{13})$	mm	4115	4415	5415	5865	6865
	Total lift	$h_{24} (h_3 + h_9)$	mm	4050	4350	5350	5800	6800
	Nominal lift	h_3	mm	3250	3550	4550	5000	6000
	Height, lowered	h_{13}	mm	65	65	65	65	65
	Additional lift ²	h_9	mm	800	800	800	800	800
	Stand height, elevated	$h_{12} (h_3 + h_7)$	mm	3483	3783	4783	5233	6233
	Picking height	$h_{28} (h_{12} + 1,600)$	mm	5083	5383	6383	6833	7833
	Height, mast extended ¹	h_4	mm	5534	5834	6834	7284	8284

EK-X telescopic mast with additional lift up to 1200 kg	Height, mast lowered	h_1	mm	2250	2450	2900	3400	3900	4400	4900	5400
	Total lift above floor	$h_{25} (h_3 + h_9 + h_{13})$	mm	3625	4025	4925	5925	6525	7525	8525	9325
	Total lift	$h_{24} (h_3 + h_9)$	mm	3565	3965	4865	5865	6465	7465	8465	9265
	Nominal lift	h_3	mm	2825	3225	4125	5125	5725	6725	7725	8525
	Height, lowered	h_{13}	mm	60	60	60	60	60	60	60	60
	Additional lift ²	h_9	mm	740	740	740	740	740	740	740	740
	Stand height, elevated	$h_{12} (h_3 + h_7)$	mm	3065	3465	4365	5365	5965	6965	7965	8765
	Picking height	$h_{28} (h_{12} + 1,600)$	mm	4665	5065	5965	6965	7565	8565	9565	10365
	Height, mast extended ¹	h_4	mm	5115	5515	6415	7415	8015	9015	10015	10815

EK-X triplex mast with additional lift up to 1200 kg	Height, mast lowered	h_1	mm	2250	2450	2900	3400	3900	4500
	Total lift above floor	$h_{25} (h_3 + h_9 + h_{13})$	mm	5210	5810	7160	7960	9460	10960
	Total lift	$h_{24} (h_3 + h_9)$	mm	5150	5750	7100	7900	9400	10900
	Nominal lift	h_3	mm	4410	5010	6360	7160	8660	10160
	Free lift	h_2	mm	1600	1800	2250	2750	3250	3850
	Height, lowered	h_{13}	mm	60	60	60	60	60	60
	Additional lift ²	h_9	mm	740	740	740	740	740	740
	Stand height, elevated	$h_{12} (h_3 + h_7)$	mm	4650	5250	6600	7400	8900	10400
	Picking height	$h_{28} (h_{12} + 1600)$	mm	6250	6850	8200	9000	10500	12000
Height, mast extended ¹	h_4	mm	6700	7300	8650	9450	10950	12450	

¹ Dimensions h_4 apply for driver roof with a clear height of 2000 mm. Intermediate heights on request.

² If no additional lift is used: $h_9 = 0$ mm



Reach height
up to 12 metres

Reach height
up to 7.8 metres

Reach height
up to 6.3 metres

EK-X

Vertical order picker
with telescopic mast
up to 1200 kg

EK-X

Vertical order picker
with telescopic mast
up to 1000 kg

EK-X 10

Vertical order picker
with telescopic mast
up to 1000 kg



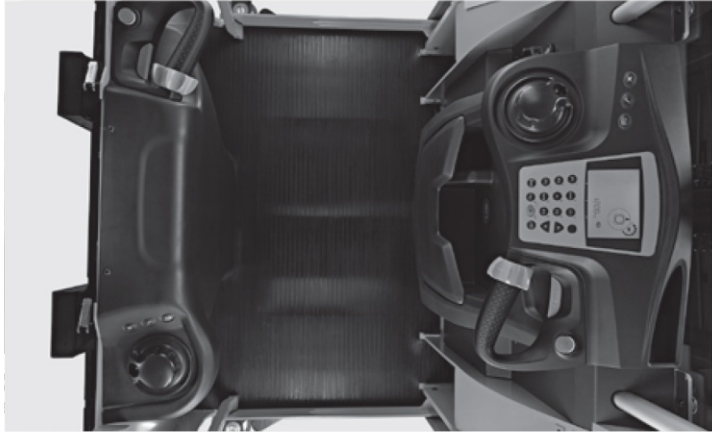

Efficient truck utilisation thanks to optional two-sided operation

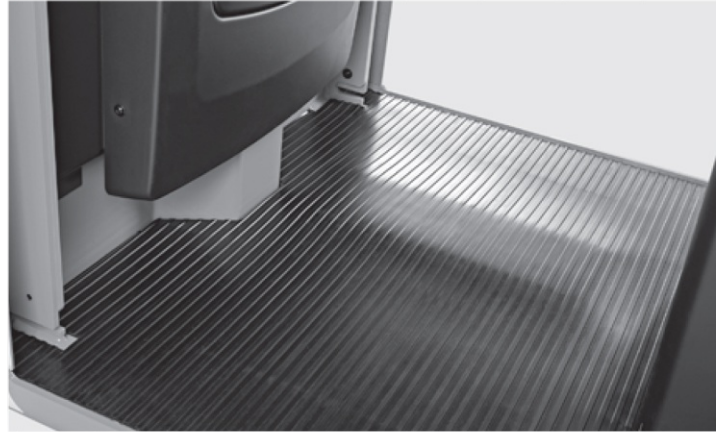

Shock-protected floor with integrated drive switch for more driving comfort without obstacles inside the operator's cab



Accessible pallet with guard as option for ergonomic order picking of heavy and bulky goods



Simple and safe pallet entry with additional barriers in load direction



Tilting bar for ergonomic order picking to the last article on the pallet



Optional operation with data terminal, printer and scanner

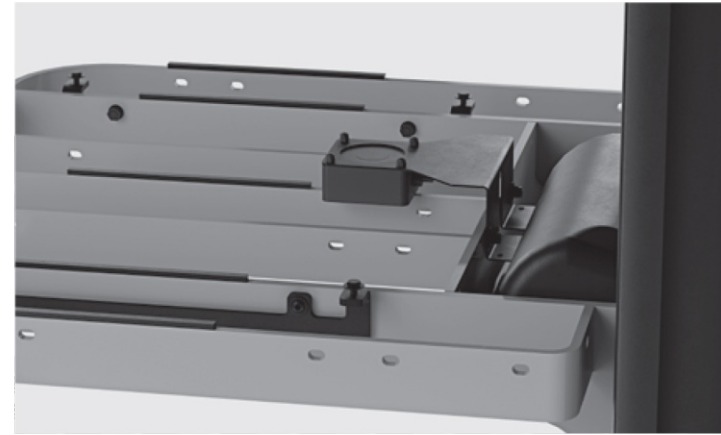

More safety for the operator, the truck and the warehouse environment thanks to optional collision protection for lifting

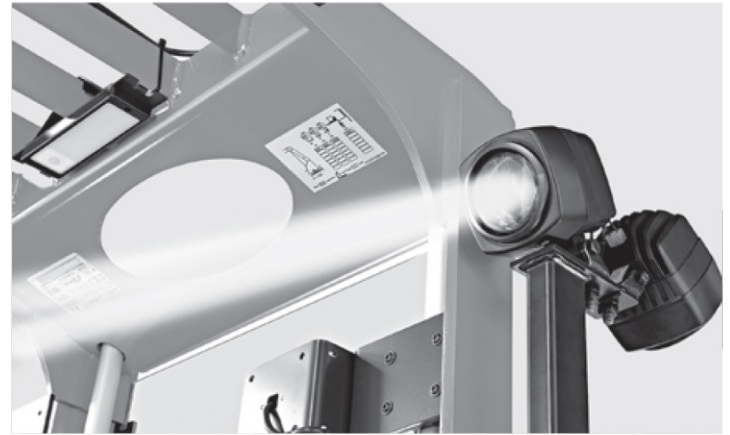

Better truck visibility with optional STILL Safety Light for more safety in the warehouse



Additional comfort for the operator thanks to optional support cushion



Simple lateral battery change optionally available, and electronic monitoring of battery locking for more operator safety



Optional personal safety system (PSS) for optimum safety in narrow aisles

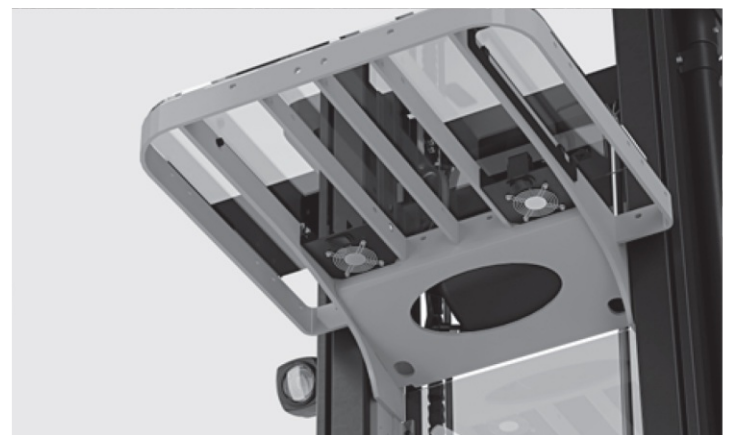

Optional fans on the overhead guard for a comfortable working temperature



Wide range of application-specific equipment options such as LED headlights, rear-view mirror and fans



Optimal ergonomic order picking height at all times thanks to additional lift

The right system for any customer requirement: STILL iGo pilot can read RFID tags and barcode labels

Custom configuration: the system can be individually adapted to any conceivable very narrow-aisle warehouse

Optimal working conditions: doing away with search processes and wasted trips relieves the burden on the operator and enables quick incorporation of new employees

iGo pilot

STILL iGo pilot - Performance profile at a glance

The iGo pilot navigation and iGo pilot safety functions link the specific warehouse topography to the trucks operating within.

The iGo pilot navigation interface communicates with the warehouse management system and combines the warehouse processes into an intelligent whole. As a result, the truck knows which high shelving location to drive to next, thus unburdening the operator. When the operator accepts the next order, the truck finds its own way through the warehouse aisles. Thanks to iGo pilot safety assistance and warning systems, which can be individually preconfigured to any warehouse,

the truck proactively adapts to its route as well as to local conditions and potential hazards. Once the truck has arrived at its destination, iGo pilot navigation stops the fork at exactly the right shelf position according to the task at hand. Once the task has been completed, the data is sent back to the warehouse management system in order to prevent order-picking errors and incorrect storage or retrieval of pallets. The result is a significant increase in handling capacity as well as increased safety thanks to networked agility.



Easy to use: destinations can be entered via scanner, terminal or online from the warehouse management system, and the process is started with just one movement of the drive lever

Supreme productivity: the truck automatically navigates to its destination along the ideal route, regardless of the experience and knowledge of the operator

Smart precision: the truck moves to exactly the right pallet position, with the possibility of preventing fork movements when not required in order to prevent storage and retrieval errors

iGo pilot navigation

iGo pilot navigation leads the operator in their very narrow aisle truck along the ideal route to the desired pallet position. This is possible thanks to a three-dimensional shelving plan that maps the specific topography of the warehouse. By comparing against this map stored in the system, the truck detects its current location in the aisle as well as its position. iGo pilot navigation adjusts to the activities of storage,

retrieval and order-picking. As soon as an order comes in, the system determines the optimal horizontal and vertical route to the desired shelf location. By means of an optical display, the operator can see his current position in relation to the destination. He can only move his truck in the direction indicated. If he is in the wrong aisle, the display will flag this up to them.

Thanks to the variety of safety functions, the driver assistant protects goods, shelves, building equipment and the truck from damage

Always ready for action: reduced downtime by avoiding impact damage and the resulting repairs

Through a simplified workflow, the driver can fully concentrate on his core activity storage and retrieval or order-picking

iGo pilot safety

If iGo pilot safety is installed, the operational safety and handling capacity of STILL very narrow aisle trucks are both significantly improved. Moreover, areas in the very narrow aisle warehouse where special safety regulations apply are defined in advance. A three-dimensional map of these areas is stored in the truck. This mapping is provided by STILL. This allows to masterfully handle obstacles in

the shelving aisle, required braking distances at the end of aisles and height restrictions during everyday operations. In addition, the truck constantly identifies its current position using the map. During its journey, the truck detects every warehouse aisle and its specific conditions and adapts to these without the operator having to intervene. The system always follows the predefined safety rules.

Truck configurations suitable for every warehouse and all goods: Millions of combination options. We determine which EK-X is suitable for you using the STILL configuration software. Based on the

dimensions of your warehouse, the loads to be transported, the necessary movement of goods and potential growth in the future, we design the perfect forklift truck with you, for you.

Batteries

24 V or 48 V,
Lead-acid or Li-Ion

Various mast variants

for storage heights of up to
12 metres

Cabin variants

Combined and comfort cabins for
more freedom of movement

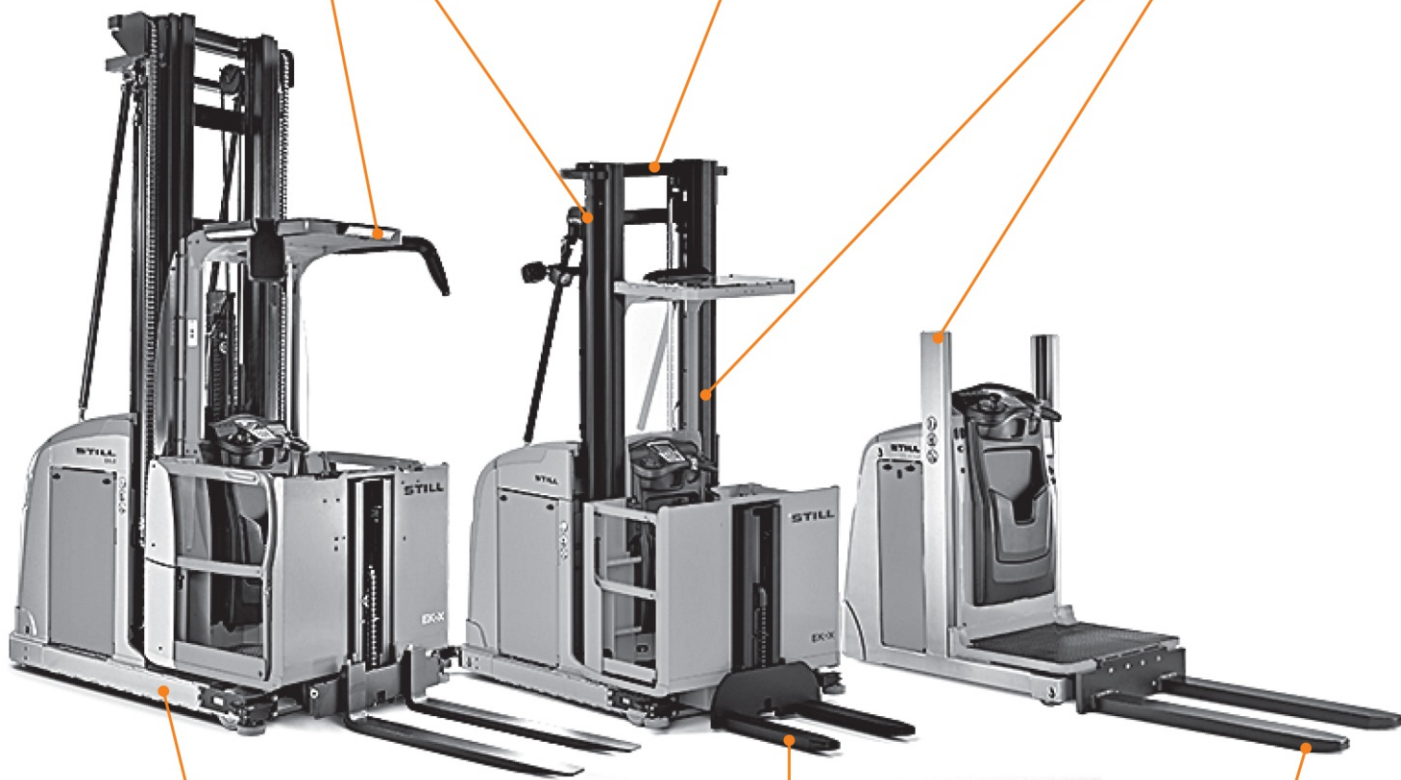

Chassis widths

from 1080 to 1580 mm

Fork carriages

welded or FEM fork carriage

Fork lengths

from 800 to 1600 mm
for a variety of loads



Simply easy

- Particularly sensitive operation and continuous control of lifting speed thanks to the latest proportional valve technology
- Intuitive control through the steering wheel or steering knob makes it easy for the operator to use all functions, customised to their needs
- Optimum user comfort provided by the spacious shock-protected stand-on platform with integrated presence switch
- Quick and easy charging at any time thanks to optional opportunity charging in lithium-ion variants



Simply powerful

- Reliable availability with powerful, low-maintenance AC drives for driving and lifting
- Optimum truck performance for every customer request thanks to individually configurable driving and lifting speeds
- Unrivalled space utilisation with a reach height of up to 12 metres
- Optimum handling performance thanks to smart OptiSpeed assistance system in a range of customised versions



Simply safe

- Operating safety guaranteed with innovative iGo pilot safety aisle safety assistant
- Optional tilting barriers allow reduced distance between truck and rack - for quick, safe and ergonomic order picking
- Safe, comfortable and healthy operator's cab with optional knee and support cushions
- Optimum truck and operation safety with electronic monitoring of battery locking



Simply flexible

- Individually configurable for a wide range of uses thanks to modular truck concept
- Accessible pallet allows the operator to enter the pallet to pick bulky and heavy goods
- Flexible operator's cab design using a mounting bar system for simple integration of tools (optional)



Simply connected

- Maximum handling with intelligent STILL iGo pilot navigation assistance system and automatic bay approach
- Simple connection to warehouse management system for optimum control of goods flow with STILL iGo pilot interface
- Optimum truck safety, access protection and damage minimisation with STILL FleetManager 4.x

Simply Efficient



Optimum use of storage space: picking heights of up to 12 metres

Large and spacious cabin for maximum freedom of movement

Optimally adjustable to any warehouse: customised solution thanks to modular design



The king of order picking: the EK-X vertical order picker sets the benchmark in terms of performance, picking height, residual load capacity, functionality and ergonomics. The EK-X forges ahead into new dimensions of efficient goods handling with driving speeds of up to 13 km/h and lifting speeds of up to 0.4 m/s.

There's a perfect EK-X for every requirement and area of use. Three different truck variants are available: The EK-X 10 is the perfect partner for vertical order picking in narrow or wide aisles, with loads of up to 1000 kg and working heights up to 6.3 metres. If you need to go higher, there's either the EK-X with a telescopic or triplex mast, with a reach height of up to 7.8 metres and a rated capacity of up to 1000 kg, or the variant with a reach height of up to 12 metres and a rated capacity of up to 1200 kg available.

All versions are equipped with the OptiSpeed system. The compact warehouse assistant guarantees the highest possible driving speed at all times, without jeopardising driving safety. Other features include an excellent field of view, a roomy shock-absorbing driver's cabin with incredible freedom of movement and a wide range of equipment options.

In short, if you want to manage your order-picking warehouse as effectively and user-friendly as possible, you can't do without an EK-X. Moreover, the different variants and modular configuration options allow the optimum EK-X to be custom-built for every warehouse.





EK-X Vertical Order Picker

Equipment Variants

	EK-X 10 b ₁ = 790 mm	EK-X 10 b ₁ = 980 mm	EK-X up to 1000 kg b ₁ = 1080-1580 mm	EK-X up to 1200 kg b ₁ = 880-1580 mm	
Operator's cab	Operator's cab for more freedom of movement	○	○	○	—
	Overhead guard height 2000/2200 mm	○	○	○	○
	Control panel on mast side/load end with steering knob/steering wheel	○	○	○	○
	Control panel with continuous electric height adjustment	—	—	—	○
	LED display	●	●	●	—
	LC display with keypad, speed and lift height display	○	○	○	●
	Tilting barriers to reduce distance to rack	○	○	○	○
	Knee cushion on picking platform with integrated storage compartment	○	○	○	○
	Fold-out and cushioned lean-to support mounted on mast side	○	○	○	○
	Comfort features in operator's cab for more storage and optimum space configuration	—	—	—	○
	Mirror module, left/right at load end, including LED headlights	○	○	—	○
	Mirror module, left/right on mast side, including LED headlights	—	○	—	○
	Mirror, left/right at load end/mast side	○	○	○	○
	LED light for operator's cab	○	○	○	○
	LED headlights to illuminate the shelves	○	○	○	○
Assistance systems	Flexible bar system for workplace configuration (mast side/load end)	○	○	○	○
	Power socket 12 V / 2 A	○	○	○	○
	Electrical and mechanical operation of data terminal	○	○	○	○
	Steering angle dependent continuous speed reduction for more safety	●	●	●	—
Drives	OptiSpeed 3.0: lift height dependent speed adjustment	—	—	—	●
	OptiSpeed 3.3: weight and load detection for speed optimisation	—	—	—	○
	STILL iGo pilot navigation: semi-automatic bay approach	—	—	—	○
	Service package for lifting	—	○	○	○
Safety	Service package for driving	—	—	○	○
	Hydraulic load wheel brake for enhanced truck performance	—	—	—	○
	STILL iGo pilot safety: tailor-made safety and flexibility in narrow aisles	—	—	—	○
	FleetManager: access authorisation, shock detection, reports	○	○	○	○
	Rescue alarm for atypical operator actions to attract attention	○	○	—	—
	Automatic braking at the aisle end with PSS, RFID tags or magnetic switch	—	○	○	○
	PSS/preparation of PSS	—	○	○	○
	Rail guide with entrance rollers	○	○	○	○
	Inductive forced guidance with automatic loop finder	—	○	○	○
	Increased residual load capacity for heavy loads at large heights	—	—	○	○
	STILL Safety Light	○	○	○	○
	Adjustable lifting override and lowering stop	○	○	○	○
	Contact-free collision protection on the overhead guard	○	○	○	○
	Acoustic warning signal when driving in the direction of the load and/or drive	○	○	○	○
	Battery	Anti-static design	○	○	○
Access via key switch, PIN code, chip or card		○	○	○	○
Roller track for lateral battery change		○	○	○	○
Battery change with forklift truck		—	—	●	●
Battery change with crane		●	●	—	—
Compartment 104 for 24 V batteries, 400-500 Ah		—	○	—	—
Compartment 134 for 24 V batteries, 480-620 Ah		—	○	—	—
Compartment 136 for 24 V batteries, 720-930 Ah		—	○	●	●
Compartment 138 for 24 V batteries, 960-1240 Ah		—	—	—	○
Compartment 153 for 24 V batteries, 360-465 Ah		●	—	—	—
Compartment 154 for 24 V batteries, 480-620 Ah		○	—	—	—
Compartment 333 for 48 V batteries, 360-465 Ah		—	—	●	●
Compartment 334 for 48 V batteries, 600-775 Ah	—	—	○	○	
Compartment 334 for 48 V lithium-ion batteries, 13.1-39.2 kWh	—	—	○	○	
Li-Ion-Ready for 48 V battery compartment	—	—	○	○	
Preparation for fast charging access	—	—	○	○	
Fast charging access	—	—	○	○	
Additional accessories	Cold store variant for temperatures of up to -30 °C	○	○	○	○
	Accessible pallet, including protective cage	○	○	○	○
	Auxiliary lift	○	○	○	○
	Pedestrian operation for floor order picking	○	○	—	—
	FEM fork carriage	○	○	○	○

● Standard ○ Option — Not available



STILL GmbH
Berzeliusstr. 10
22113 Hamburg
Germany

Tel.: +49 40 73 39 20 00
Fax: +49 40 73 39 20 01
info@still.de

For further information please visit
www.still.eu



Gemini Equipment And Rentals Pvt. Ltd.

1706-1709, The Corporate Park 17th Floor Plot No-14-15
Vashi Navi Mumbai -400705, India.
Email id : info@gear-india.com | Contact No: +918451934343 |
Website: www.gear-india.com

STILL is certified in the following
areas: Quality management,
occupational safety, environmental
protection and energy management.



ISM# ISO 9001# ISO 14001
OHSAS 18001# ISO 50001

first in intralogistics