

EXH-SF and EXH-S Technical Data

Low Lift Pallet Trucks with Driver's Stand-on Platform

EXH-SF 20/Li-Ion

EXH-SF 25/Li-Ion

EXH-S 20/Li-Ion

EXH-S 25/Li-Ion





				STILL	STILL	STILL	STILL		
Features	1.1	Manufacturer							
	1.2	Manufacturer's type designation		EXH-SF 20/Li-Ion	EXH-SF 25/Li-Ion	EXH-S 20/Li-Ion	EXH-S 25/Li-Ion		
		Platform type		Hinged stand-on platform	Hinged stand-on platform	Rear access/backrest/side access	Rear access/backrest/side access		
	1.3	Drive		Electric	Electric	Electric	Electric		
	1.4	Operation		Standing/pedestrian	Standing/pedestrian	Standing	Standing		
	1.5	Capacity/load	Q	kg	2000	2500	2000	2500	
	1.6	Load centre distance	c	mm	600	600	600	600	
	1.8	Load distance	x	mm	895 ²	895 ²	905 ²	905 ²	
	1.9	Wheel base	y	mm	1408 ²	1408 ²	1408 ²	1408 ²	
Weights	2.1	Service weight (incl. battery)		kg	875	875	870		
	2.2	Axle load, laden	drive end/load end	kg	983/1920	983/1920	1175/1695	1288/2082	
	2.3	Axle load, unladen	drive end/load end	kg	710/165	710/165	720/150	720/150	
Tyres (chassis)	3.1	Tyres			Polyurethane	Polyurethane	Polyurethane		
	3.2	Tyre size	drive end	mm	Ø 230 x 90	Ø 230 x 90	Ø 230 x 90	Ø 230 x 90	
	3.3	Tyre size	load end	mm	Ø 85 x 110 (Ø 85 x 85) ¹	Ø 85 x 110 (Ø 85 x 85) ¹	Ø 85 x 110 (Ø 85 x 85) ¹	Ø 85 x 110 (Ø 85 x 85) ¹	
	3.4	Support rollers	drive end	mm	2x Ø 125 x 60	2x Ø 125 x 60	2x Ø 125 x 60	2x Ø 125 x 60	
	3.5	Number of wheels (x = driven)	drive end/load end		1x + 2/4	1x + 2/4	1x + 2/2 (1x + 2/4)	1x + 2/2 (1x + 2/4)	
	3.6	Tread	drive end/load end	b ₁₀ /b ₁₁	mm	502/380	502/380	502/380	502/380
Dimensions	4.4	Lift		h ₃	mm	125	125	125	
	4.8	Standing height (platform)		h ₇	mm	220	220	220	
	4.9	Tiller handle height in driving position		min./max.	h ₁₄	mm	1210/1440	1210/1440	
	4.15	Fork height, lowered			h ₁₃	mm	86	86	
	4.19	Overall length	platform closed/open	l ₁	mm	1957/2395 ⁴	1957/2395 ⁴	2320 ^{5,6}	2320 ^{5,6}
	4.20	Length including fork backs	platform closed/open	l ₂	mm	800/1238 ⁴	800/1238 ⁴	1170 ^{5,6}	1170 ^{5,6}
	4.21	Total width			b ₁	mm	720	720	720
	4.22	Fork dimensions	DIN ISO 2331	s/e/l	mm	55/165/1150	55/165/1150	55/165/1150	55/165/1150
	4.25	Overall fork width			b ₅	mm	560	560	560
	4.32	Ground clearance, centre of wheel base			m ₂	mm	30	35	35
	4.34	Working aisle width with 800 x 1200 pallet lengthways	platform open	A _{st3}	mm	2844 ^{2,4}	2844 ^{2,4}	2793 ^{2,4}	2793 ^{2,4}
	4.34.1	Working aisle width with 1000 x 1200 pallet crossways	platform open	A _{st}	mm	2926 ^{2,4}	2926 ^{2,4}	2876 ^{2,4}	2876 ^{2,4}
	4.35	Turning radius	platform open	W _a	mm	2140 ^{2,4}	1700/2140 ^{2,4}	2095 ^{2,5,7}	2095 ^{2,5,7}
Performance	5.1	Travel speed	laden/unladen	km/h	6/6 (8/8, 10/10) ³	10/12 (10/14) ³	8/8 (10/12) ³	10/12 (10/14) ³	
	5.2	Lifting speed	laden/unladen	m/s	0.05/0.06	0.05/0.06	0.036/0.046	0.028/0.036	
	5.3	Lowering speed	laden/unladen	m/s	0.1/0.08	0.1/0.08	0.09/0.089	0.066/0.072	
	5.8	Max. gradeability	laden/unladen	%	12/20	12/20	13/20	11/20	
	5.10	Service brake				Electromagnetic	Electromagnetic	Electromagnetic	
Electric engine	6.1	Drive motor, rating S2 60 min		kW	2.3	3.0	3.0	3.0	
	6.2	Lift motor, rating at S3 15%		kW	1.2	2.2	1.2	1.5	
	6.3	Battery according to DIN 43531/35/36: A, B, C, no			DIN 43535 3PzS	DIN 43535 3PzS	DIN 43535 3PzS	DIN 43535 3PzS	
	6.4	Battery voltage/nominal capacity K _s		V/Ah	24/375	24/375	24/375 // Li-Ion 24/410	24/375 // Li-Ion 24/410	
	6.5	Battery weight ±5% (depends on make)		kg	290	290	290	290	
	6.6	Energy consumption according to VDI cycle		kWh/h	0.45	0.5 (0.56) ³	0.43	0.51	
Misc.	8.1	Drive control			AC control	AC control	AC control	AC control	
	8.4	Sound level at driver's ear		dB(A)	62	62	69	69	

¹ With tandem load rollers

² Elevated initial lift, lowered initial lift +70 mm

³ With Power Plus

⁴ With 4PzS/400-500-Ah battery +75 mm; with 2PzS/250-Ah battery -75 mm

⁵ For compartment 70: +75 mm for 4PzS, +150 mm for 5PzS

⁶ +75 mm for backrest/side access

⁷ +55 mm for backrest/side access

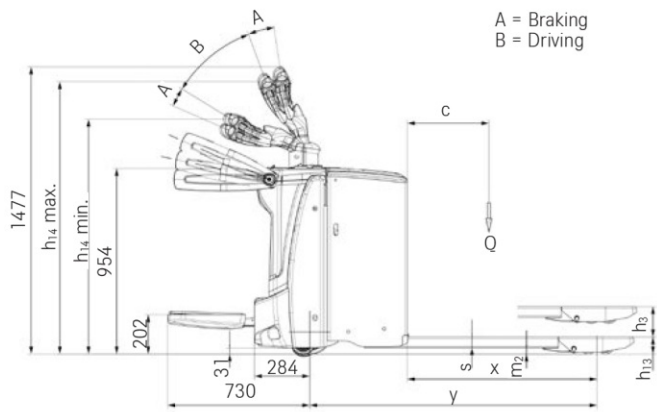

Side view EXH-SF

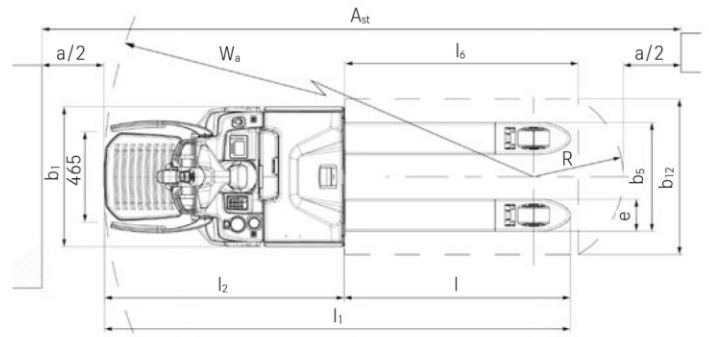

Top view EXH-SF





Up to 2,500 kg lifting capacity and an impressive top speed of 14 km/h



Adjustable side arms and air-sprung stand-on platform adjustable to individual driver weight

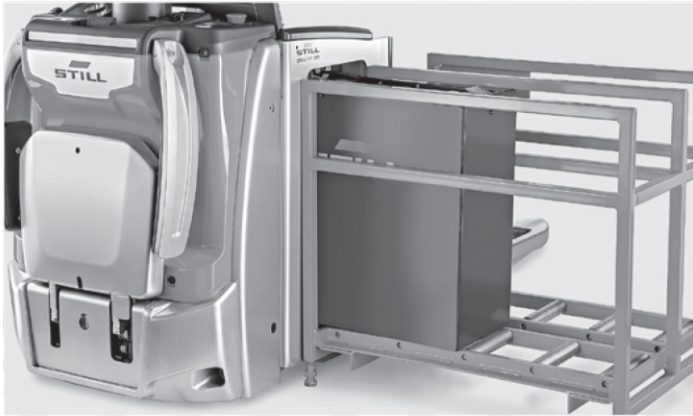

The innovative battery plug lock enables fast battery replacement, without the risk of jamming



The colour display with language-independent symbols shows all of the important functions at a glance



Optimum view of the fork tips allows a high and safe handling performance



Increased operational hours thanks to fast interim charging with optional STILL Li-ion technology



Powerful on ramps: slanted chassis design enables powerful driving on ramps



A variety of access options and a stand-on platform cushioning that can be adjusted by rocker switch (+/-)

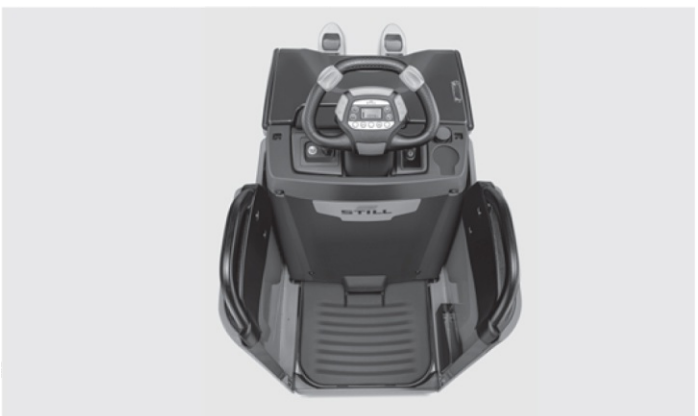

Rear access for extra safety when loading and unloading, and when driving up ramps



Side access for longer transport distances



Backrest for frequent order picking, also optionally for all models an individually adjustable, air cushioned stand-on platform



Thanks to the height-adjustable STILL Easy Drive steering wheel, all functions can be operated with ergonomic controls by right- and left-handed operators without changing grip

Superb handling performance: a top speed of 14 km/h and a maximum lifting capacity of 2,500 kg

Back-friendly: air-cushioned stand-on platform adjustable to individual weight with adjustable side arms

Powerful driving on ramps: hydraulically sprung support wheels for best traction



EXH-SF

Speed, ergonomics, compact design - the EXH-SF pallet truck with a hinged stand-on platform is the perfect combination of all these qualities. With a maximum lifting capacity of 2,500 kg and an impressive top speed of 14 km/h, the EXH-SF demonstrates superior handling power. The air-cushioned stand-on platform with integrated compressor keeps work back-friendly at all times. Due to its sprung support wheels the smart warehouse organiser crosses ramps comfortably, safely and with optimum traction. Furthermore,

the EXH-SF helps to save valuable warehouse space: with a total width of just 720 mm, the pallet truck is narrower than a Europallet and can be manoeuvred precisely through the narrowest of aisles. Do you need a truck that is operational 24 hours a day? With the STILL Li-ion technology, even the shortest breaks are sufficient to charge the EXH-SF. As different battery sizes are available depending on your individual needs, any customer requirement as well as multi-shift operations can be realised.



Ergonomic back protection thanks to individually adjustable air-cushioned driver's stand-on platform

High and flexible handling capacity: a maximum speed of 14 km/h and a lifting capacity of 2,500 kg

Safe handling in confined spaces thanks to a chassis that is only 720 mm narrow

Intuitive operating concept: height-adjustable STILL Easy Drive steering wheel provides easy-access control without having to change to grip



EXH-S

Efficient performance, safe and convenient operation, reliable flexibility - the EXH-S pallet truck combines all of these features to perfection. With a maximum lifting capacity of 2,500 kg, a swift top speed of 14 km/h and the ability to move two pallets at once thanks to the extra-long forks, the EXH-S features unrivalled performance. Thanks to the intuitive operating concept, you can rely on the height-adjustable STILL Easy Drive steering wheel with integrated display and rocker switches at all times. This feature ensures that left- and right-handed operators always have full control of all functions, without having

to change grip. The optional, individually adjustable, air-cushioned stand-on platform also provides optimal protection for the operator's back, even in the toughest applications. Speaking of applications, the EXH-S equips you for any storage situation and ensures you benefit from flexibility when it comes to configuration variants. All truck variants have an ultra-robust chassis. This provides extra protection for demanding ramp applications, for example. Those who choose the lithium-ion variant as an option can interim charge the battery at any time and benefit from maximum flexibility.



Simply easy

- Smooth steering and intuitive operation of all functions for left- and right-handed operators with STILL Easy Drive steering wheel
- Easy access and optimal protection for the operator's back and joints: low access point and adjustable, air-cushioned stand-on platform with integrated compressor available as an option
- Optional built-in charger for decentralised charging at every power socket
- Optimal utilisation of storage space: compact dimensions and high manoeuvrability facilitate narrow working aisles

Simply powerful

- Fast goods handling: up to 2,500 kg lifting capacity and an optional maximum speed of 14 km/h for the EXH-S 25
- Built for continuous operation: reliable and low-maintenance drive
- Swift, safe movement on ramps: high-powered drive and lift motor and 5-wheel chassis with sprung support wheels
- Instant charging: lithium-ion model achieves 50 percent charge level in only 30 minutes and is fully charged in only 90 minutes
- Withstands even the toughest applications: robust, durable chassis made from solid steel

Simply safe

- Simply work with precision thanks to unobstructed field of vision: free view mast and centrally positioned tiller
- Accidental roll-back impossible: automatic stop function even on ramps
- Fast and safe cornering: Curve Speed Control automatically adapts speed to the steering angle when cornering
- Only moves off once the operator is standing safely: optional foot sensor determines whether the feet are within the truck's contour
- Safe load handling in confined spaces thanks to compact dimensions

Simply flexible

- Suitable driving programmes for any application, from maximum handling power to optimal efficiency: ECO, BOOST or Blue-Q
- Ready for use at all times: battery capacities up to 500 Ah and optional STILL lithium-ion battery for round-the-clock availability
- Decentralised and flexible charging at any power socket with the optional built-in charger
- Flexibly configurable driver's cab for various main applications, from frequent ramp driving through to long transport distances: rear access, side access or backrest

Simply connected

- Versatile, flexible access control with FleetManager 4.x
- Fast service analysis and parametrisation of settings thanks to CAN bus interface
- Easy integration into material flow management system thanks to MMS provision

Simply Efficient





EXH-SF and EXH-S Low Lift Pallet Trucks with Driver's Stand-on Platform

Equipment Variants

	EXH-SF 20	EXH-SF 25	EXH-S 20	EXH-S 25	
General	Integrated storage options	●	●	●	●
	Control element assembly suitable for both left and right-handed operators	●	●	●	●
	LED-battery status display and operating hours meter	○	○	○	○
	Colour display and control unit for selecting the driving programme, including Blue-Q	●	●	—	—
	Cold storage version	○	○	○	○
	Powerful three phase drive motor for very low maintenance costs	●	●	●	●
	Side protection bars	○	●	—	—
	Side protection panel	—	—	●	●
	Accessories bracket on the drive side	○	○	○	○
	Hinged platform	●	●	—	—
	Mechanically sprung stand-on platform	●	—	●	—
	Air-sprung stand-on platform	○	●	○	●
	Air-sprung stand-on platform with built-in compressor for suspension adjustment	○	○	○	○
	Initial lift	●	●	●	●
	Adjustable DIN-A4 writing pad	○	○	○	○
	Preparation Material Management System (MMS) and data transfer	○	○	○	○
	Tyres	Drive wheel tyres, polyurethane	●	●	●
Drive wheel tyres, polyurethane, profiled		○	○	○	○
Drive wheel tyres, solid rubber		○	○	○	○
Drive wheel tyres, solid rubber, profiled		○	○	○	○
Load roller tyres, polyurethane, single		●	●	●	●
Load roller tyres, polyurethane, tandem		○	○	○	○
Safety	Access authorisation (key)	●	●	●	●
	Access authorisation (digicode)	○	○	○	○
	FleetManager: access authorisation, shock detection, reports	○	○	○	○
	Curve Speed Control: speed reduction when driving around corners	●	●	●	●
	STILL Combi tiller: variable tiller length for an adequate distance between driver and equipment	○	○	—	—
	Headlights	○	○	○	○
Battery	STILL Safety Light	○	○	○	○
	Load backrest	○	○	○	○
	Sheet steel battery cover	●	●	●	●
	Battery compartment for battery up to 250 Ah, for changing batteries with a crane	○	○	—	—
	Battery compartment for 300-375 Ah battery, for changing batteries with a crane	●	●	●	●
	Battery compartment for 400-500 Ah battery, for changing batteries with a crane	○	○	○	○
	Battery compartment for battery up to 250 Ah, for changing batteries with a roller track and changing frame	○	○	—	—
	Battery compartment for 300-375 Ah battery, for changing batteries with a roller track and changing frame	○	○	○	○
	Battery compartment for 400-500 Ah battery, for changing batteries with a roller track and changing frame	○	○	○	○
Battery compartment for battery up to 620 Ah, for changing batteries using a roller track and changing frame	—	—	○	○	
205 Ah STILL Li-Ion battery	○	○	○	○	
410 Ah STILL Li-Ion battery	○	○	○	○	
Built-in charger for Li-ion batteries	○	○	○	○	

● Standard ○ Option — Not available



STILL GmbH
Berzeliusstr. 10
22113 Hamburg
Germany
Tel.: +49 40 73 39 20 00
Fax: +49 40 73 39 20 01
info@still.de

For further information please visit
www.still.eu



Gemini Equipment And Rentals Pvt. Ltd.

1706-1709, The Corporate Park 17th Floor Plot No-14-15
Vashi Navi Mumbai -400705, India.
Email id : info@gear-india.com | Contact No: +918451934343 |
Website: www.gear-india.com

STILL is certified in the following areas: Quality management, occupational safety, environmental protection and energy management.



first in intralogistics