

SXD, FXD N and FXD Technical Data Double Deck High Lift Pallet Trucks

SXD 20/Li-Ion

FXD 20 N/Li-Ion

FXD 20/Li-Ion





				STILL	STILL	STILL
Features	1.1	Manufacturer				
	1.2	Manufacturer's model designation		SXD 20/Li-Ion	FXD 20 N/Li-Ion	FXD 20/Li-Ion
	1.3	Drive		Electric	Electric	Electric
	1.4	Operation		Stand-on	Seated truck	Seated truck
	1.5	Nominal load		Q	kg	2000
	1.5.1	Capacity/load	as a double decker	Q _i + Q _m	kg	1000+800
	1.6	Load centre distance		c	mm	600
	1.8	Load distance		x	mm	860 ³
	1.9	Wheel base		y	mm	1780 ³
Weights	2.1	Service weight incl. battery			kg	1348 ¹
	2.2	Axle load, laden		drive end/load end	kg	1273/2075 ¹
	2.3	Axle load, unladen		drive end/load end	kg	943/405
Wheels/chassis	3.1	Tyres				Polyurethane
	3.2	Tyre size		drive end	∅ x l	mm
	3.3	Tyre size		load end	∅ x l	mm
	3.4	Support rollers size		∅ x l	mm	2x 140x50
	3.5	Number of wheels (x = driven)		drive end/load end		1x + 1/2 (1x + 1/4) ²
	3.6	Tread width		drive end/load end	b ₁₀ /b ₁₁	mm
Dimensions	4.2	Height		mast lowered	h ₁	mm
	4.3	Free lift			h ₂	mm
	4.4	Lift			h ₃	mm
	4.5	Height ⁴		mast extended	h ₄	mm
	4.6	Initial lift			h ₅	mm
	4.7	Seat height rel. to SIP			h ₇	mm
	4.15	Fork height lowered			h ₁₃	mm
	4.19	Total length			l ₁	mm
	4.20	Length including fork backs			l ₂	mm
	4.21	Total width			b ₁	mm
	4.22	Fork dimensions			s/e/l	mm
	4.23	Wheel dimensions			s/e/l	mm
	4.24	Fork carriage width			b ₃	mm
	4.25	Overall fork width			b ₅	mm
	4.26	Width between wheel arms			b ₄	mm
4.32	Ground clearance, centre of wheel base			m ₂	mm	
4.34	Working aisle width with 800 x 1200 pallet lengthways			A _{st}	mm	
4.35	Turning radius			W _a	mm	
Performance data	5.1	Driving speed		laden/unladen	km/h	10/10
	5.2	Lifting speed		laden/unladen	m/s	0.013/0.023
	5.3	Lifting speed, initial lift		laden/unladen	m/s	0.064/0.089
	5.3	Lowering speed		laden/unladen	m/s	0.045/0.032
		Lowering speed, initial lift		laden/unladen	m/s	0.073/0.075
	5.8	Max. gradeability		0 kg/1200 kg/2000 kg	%	20/15/13
5.9	Service brake				Electromagnetic	
Electric engine	6.1	Drive motor, rating S2 = 60 min			kW	3.0
	6.2	Lifting motor, rating S3 = 10%			kW	2.3
	6.3	Battery according to DIN 43531/35/36 A, B, C, no				3PzS
	6.4	Battery voltage/rated capacity K _s			V/Ah	24/300 Li-Ion: 23/205
	6.5	Battery weight ±5% (depends on manufacturer)			kg	290
	6.6	Energy consumption according to VDI cycle			kWh/h	1.01
	6.7	Handling rate acc. to VDI cycle			t/h	136
Misc.	8.1	Transmission control				AC control
	10.7	Noise level (at operator's ear)			dB(A)	67
	Human vibrations: acceleration in accordance with EN 13059			m/s ²	0.74	

¹ With 3PzS battery; +75 mm 4PzS battery SXD 20; +100 mm 4PzS battery FXD 20 N/FXD 20

² With tandem rollers

³ Initial lift lowered

⁴ With load backrest +566 mm

Mast Table

SXD 20	Telescopic mast					HiLo mast							
	Height	h ₁	mm	1240	1315	1415	1465	1515	1240	1315	1415	1465	1515
Mast height with used free lift	h ₁ '	mm	1315	1390	1490	1540	1590	-	-	-	-	-	-
Free lift	h ₂	mm	150	150	150	150	150	720	795	895	945	995	
Lift	h ₃	mm	1574	1724	1924	2024	2124	1574	1724	1924	2024	2124	
Height, mast extended ⁴	h ₄	mm	2094	2244	2444	2544	2644	2094	2244	2444	2544	2644	

Mast Tables

FXD 20 N			Telescopic mast		HiLo mast		
	Height	h ₁	mm	1415	1665	1415	1665
	Mast height with used free lift	h ₁ '	mm	1490	1740	-	-
	Free lift	h ₂	mm	150	150	895	1145
	Lift	h ₃	mm	1844	2344	1844	2344
	Height, mast extended ⁴	h ₄	mm	2364	2864	2444	2864

FXD 20			Telescopic mast			HiLo mast			
	Height	h ₁	mm	1415	1665	1915	1415	1665	1915
	Mast height with used free lift	h ₁ '	mm	1490	1740	1990	-	-	-
	Free lift	h ₂	mm	150	150	150	895	1145	1395
	Lift	h ₃	mm	1844	2344	2844	1844	2344	2844
	Height, mast extended ⁴	h ₄	mm	2364	2864	3364	2364	2864	3364

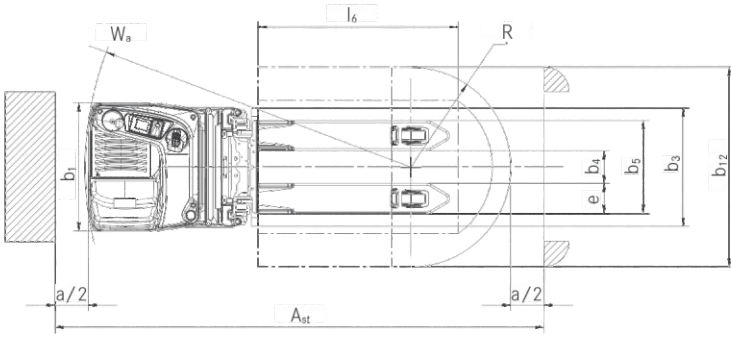

Top view SXD

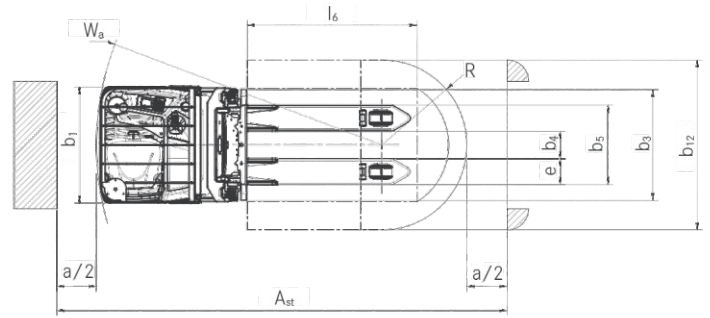

Top view FXD N

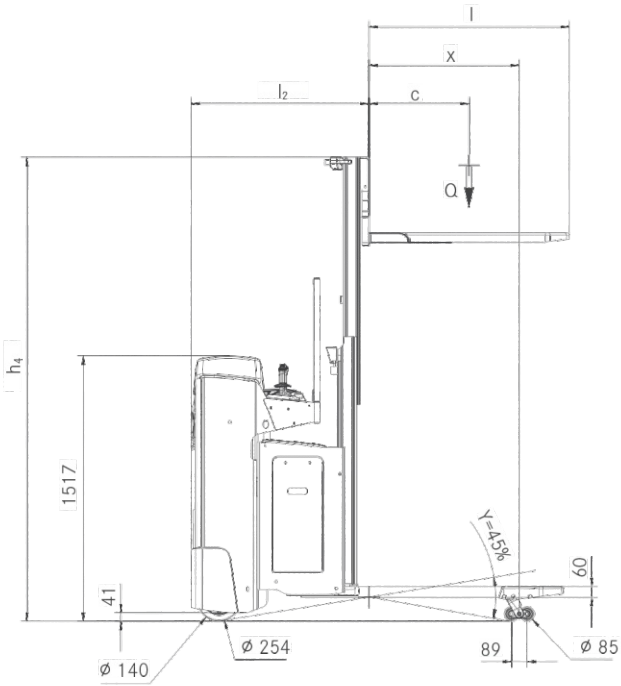

Side view SXD

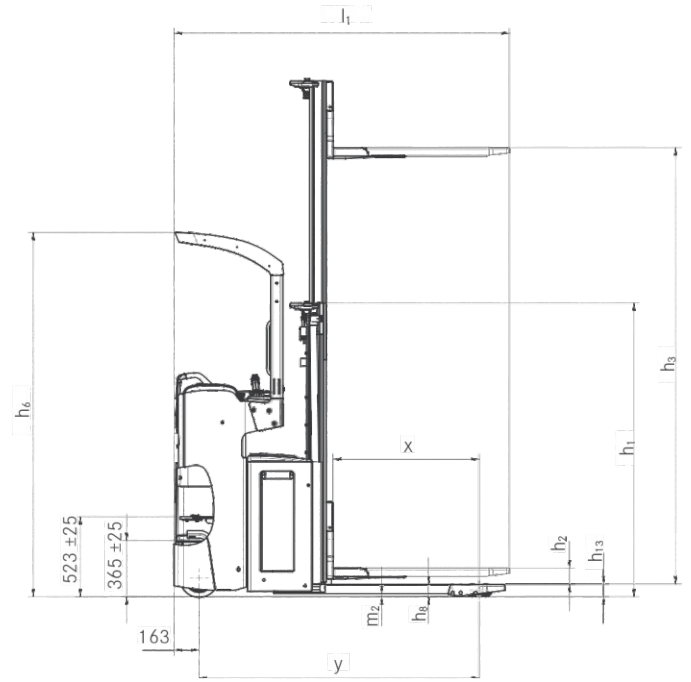

Side view FXD N

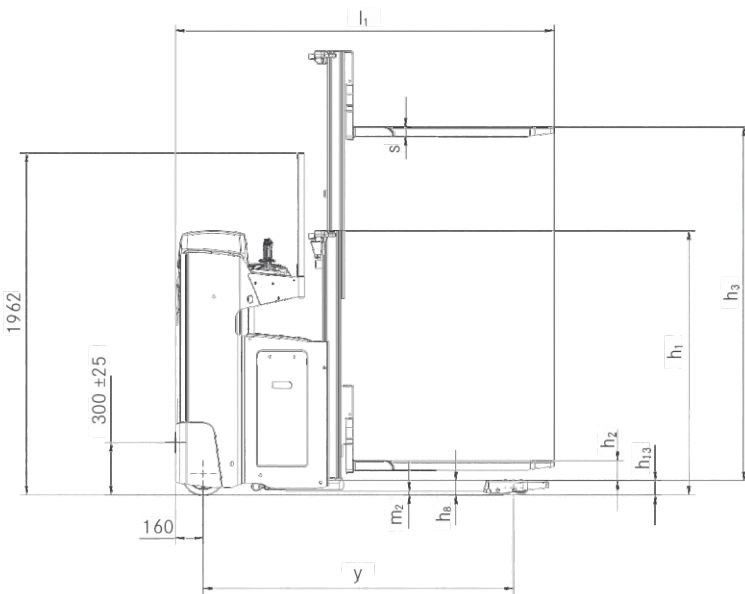

Side view SXD

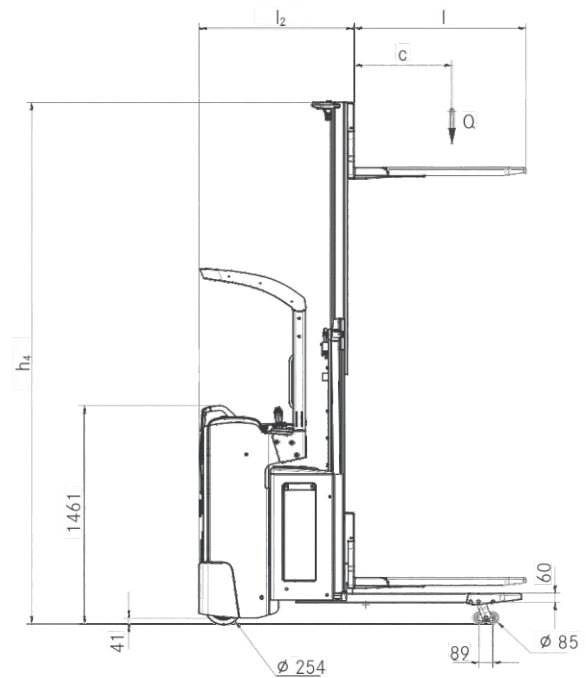

Side view FXD N

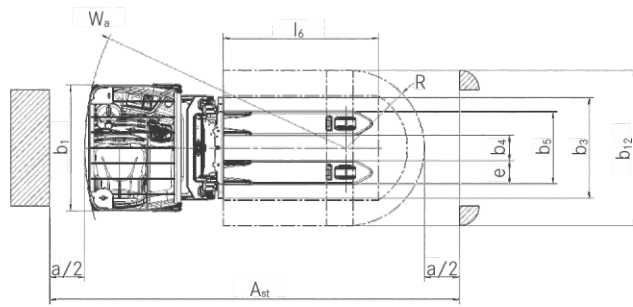

Top view FXD

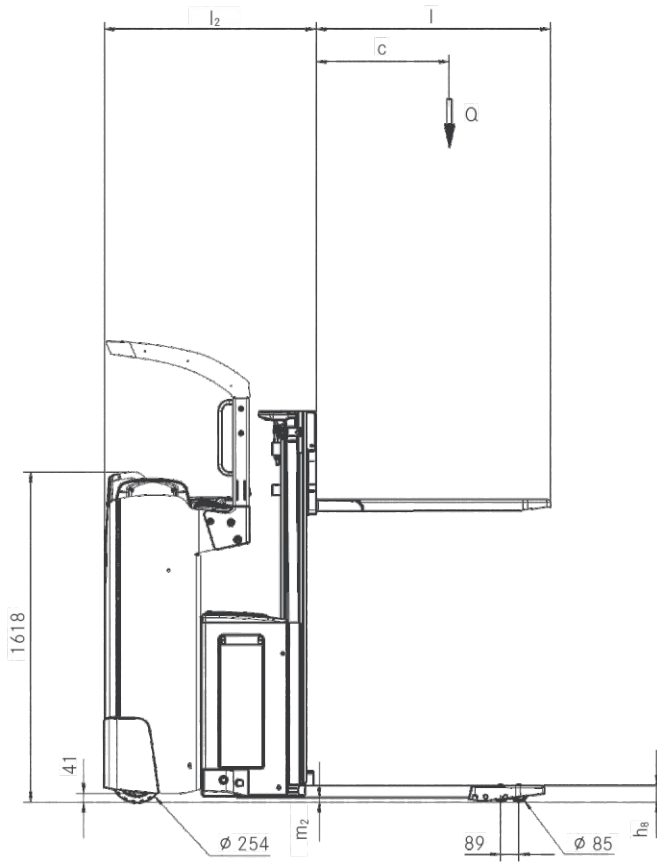

Side view FXD

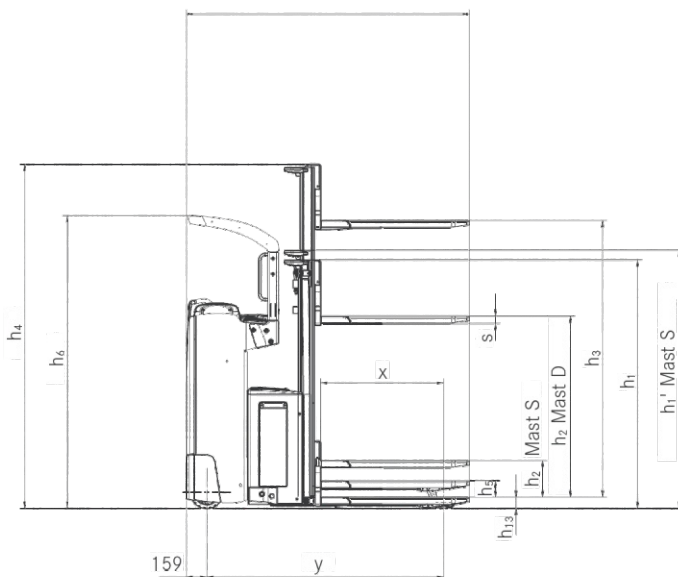

Side view FXD



Perfect view of the prongs increases the reloading rate and safety



Precise driving, lifting and lowering with standard joystick, without having to keep changing hands for fatigue-free operation



Edge-free battery door for operation in confined spaces



Maximum comfort: The steering wheel can be positioned on the left- or right-hand side for individual adjustments



Back-friendly even on longer stretches thanks to the sprung foot plate



Standard lateral battery change for maximum availability and ergonomics



Always safe travel thanks to the standard overhead guard



Optional Joystick 4Plus for lift, lowering and transmission control without having to change hands for fatigue-free operation



Automatic counterbalancing for uneven floors and best possible driving behaviour



Narrow overhead guard profile for optimum view when stacking and dispatching



Flexible and powerful thanks to the maximum lifting capacity of up to 1,200 kg on the mast



Higher handling rate: up to 2,000 kg lifting capacity and 12 km/h speed



Maximum availability because of Li-Ion technology and interim charging

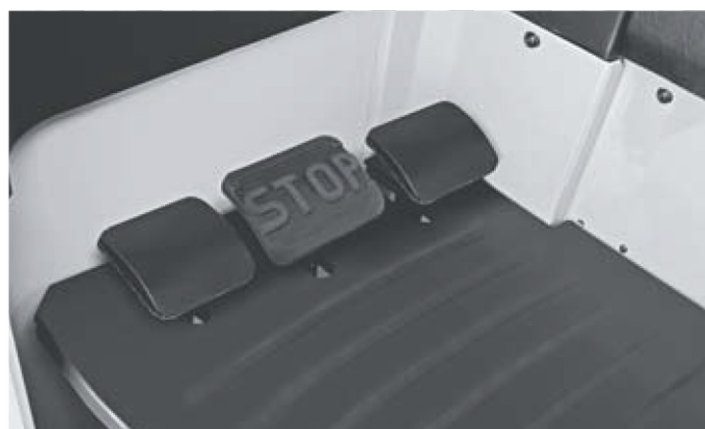

Precision down to your toes with pedals for fast direction changes



Particularly spacious driver workstation with integrated storage option and comfort seat



Colour display and control unit shows battery status, direction of travel and additional information



Powerful and compact: Lifting capacity of up to 2,000 kg and narrow chassis with a width of only 770 mm

Powerful movement on ramps to increase handling capacity and high level of safety because of optional chassis counterbalance

Intuitive operator guidance as the control unit can be attached on the left or right operating side



SXD

The SXD is a truck for the most demanding applications. The SXD quickly and safely handles double-deck storage, loading and unloading lorries or even horizontal transport. It saves time by transporting two standard pallets at once to your chosen location. Loads are incredibly easy to move even on ramps, due to the optional counterbalance for the chassis. The SXD's strength lies in its flexibility. As a double deck truck, the SXD can transport 800 kg on the mast and, at the same time, 1,200 kg on the initial lift. If the initial lift is not used, the SXD can also function as a high lift pallet truck for up to 1,200 kg.

As a high lift pallet truck, the SXD transports even 2,000 kg on a pallet. This saves time and increases the handling performance. In addition, more, the SXD is also ideally suited as a work or lifting table, and for shelf-filling. Its individuality is also reflected in the details: The steering wheel on the driver's stand can be mounted on the right- or left-hand side to take individual operator preferences into account. This customisation increases safety in the warehouse, as the truck can be operated as preferred. The compact dimensions, enable it to be used in the smallest of spaces, and the cushioned driver's operating platform complete the whole package and make the SXD the perfect warehouse assistant.

Performance and comfort: Speed up to 10 km/h and ergonomic driver's seat

Maximum precision: Joystick 4Plus and clear view of the prongs

Ergonomic down to the finest detail: Height-adjustable foot plate and variable operating concept for fatigue-free operation



FXD 20 N

Doubly good warehouse organiser: The double deck high lift pallet truck FXD 20 N can transport two pallets at once. In total, it moves loads of up to 2,000 kg, 1,000 kg on the initial lift and 1,000 kg on the forks. The latter raise the pallets to a height of more than 2.30 m. This makes the FXD 20 N perfect for the twice as fast transport of pressure-sensitive goods such as food. The high lift pallet truck works not only especially fast but also for a particularly long time: Owing to the maximum battery capacity of 500 Ah, the logistical powerhouse effortlessly manages a full shift.

If you opt for the modern Li-Ion technology and use short breaks for interim charging, you even ensure 24-hour availability. Things may get tight in the warehouse, but never for the operator of an FXD 20 N, which can be manoeuvred smoothly and precisely, even in confined spaces, with the flexibly adjustable electrical steering unit. Even the number of steering wheel turns needed for a 180-degree change of direction is individually adjustable. Safety is ensured with features such as the automatic speed reduction when cornering and the standard overhead guard.

High reloading performance: Lifting capacity up to 2,000 kg and speed up to 12 km/h

Optimum comfort due to the extra spacious driver workstation with comfort seat

Maximum availability with battery capacities of up to 620 Ah and Li-Ion technology



FXD 20

Handling rate combined with comfort: that is what the FXD 20 double deck high lift pallet truck stands for. It can transport two non-stackable pallets at once. The maximum lifting capacity of up to 2,000 kg coupled with a speed of up to 12 km/h guarantees maximum handling performance. With a mast height of more than 2.3 m and a maximum lifting capacity of up to 1,200 kg on the mast, the FXD 20 is just as versatile as it is powerful. Its particular strengths lie in multi-shift operation, because with the lateral battery change and battery

capacities of up to 620 Ah the FXD 20 is available around the clock. Optionally, the Li-Ion technology allows for rapid (interim) charging without removing the battery. The optional pedals enable precise manoeuvring in the aisles. The lifting functions are operated with the Joystick 4Plus. Due to the ergonomic design of the joystick fatigue-free operation is guaranteed. Also, the automatic speed reduction when driving around corners and the speed adaptation based on mast height ensure maximum safety.

Extensive Equipment

Power

- Effective goods handling: Driving speed up to 12 km/h
- High handling rate thanks to stacking on two levels with a load capacity of up to 2,000 kg
- Enough power for multiple shifts: High battery capacity of up to 620 Ah and lateral battery change available
- Always available: The Li-Ion battery bundles large amounts of energy and allows for quick and easy interim charging
- The right driving programme for all situations: ECO, BOOST or Blue-Q - from maximum handling rate to highest efficiency

Precision

- Precise handling of all functions with the joystick without having to keep changing hands
- Fatigue-free operation: Precise and intuitive electrical steering unit
- Sensitive and intuitive operation with the proportional valve technology for lifting and lowering
- Everything in view, all the time: Display shows battery status, date and time
- Precision down to the toes: Pedals for fast direction changes in the FXH 20

Ergonomics

- Reduced impact when driving over uneven surfaces with cushioned driver's seat
- Maximum operator comfort thanks to height-adjustable foot plate in the FXD 20 N and FXD 20
- All functions can be easily operated using the Joystick 4Plus without having to keep changing hands
- Ergonomic and intuitive operation: Option of steering wheel or steering knob

Compactness

- Ideal in the smallest of spaces: Compact truck dimensions and very high manoeuvrability allow for optimum use of warehouse space
- High pallet reloading rate: Flexible application options thanks to the compact dimensions
- At home in any aisle: Truck widths of 770 mm, 820 mm or 970 mm to choose from

Safety

- Extremely safe around corners: Curve speed control automatically adapts speed to the steering angle when cornering
- Extremely safe to drive due to speed limiter based on mast height
- High stability on uneven surfaces with the automatic counterbalance
- The large step and low entry make it safe and easy to get into
- Versatile, flexible access control with FleetManager 4.x
- Protection from all sides: Overhead guard of the FXD 20 N and FXD 20 for increased working safety

Environmental Responsibility

- Energy savings of up to seven percent at the touch of a button with no loss of performance: Blue-Q efficiency mode
- Low operating costs: Low energy consumption and long maintenance intervals
- Low noise emissions due to extremely quiet drive and lifting motor



SXD, FXD N and FXD Double Deck High Lift Pallet Trucks

Equipment Variants

	SXD 20	FXD 20 N	FXD 20
General	Cushioned driver's seat	—	●
	Height-adjustable foot plate	—	●
	Cushioned foot plate	●	—
	Height-adjustable backrest	●	—
	Colour display and control unit	●	●
	Integrated storage option	●	●
	Fully electric steering	●	●
	Fully electric steering with reversing function	○	○
	Hydraulic operation via fixed joystick	●	●
	Hydraulic operation via Joystick 4Plus	—	○
	Driving with single pedal	—	—
	Driving with dual pedal	—	—
	Steering on the right-hand side	○	—
	Steering knob on the left-hand side	○	○
	High-performance AC drive motor	●	●
	Cold store variant	○	○
	Accessory rods on the right- or left-hand side or on both sides	○	○
	DIN A4 writing surface	○	○
	Preparation for data terminal	○	○
	Data transfer via Bluetooth or GPRS	○	○
	Low entry and handle	●	●
	Initial lift	●	●
	Mast	Telescopic mast	○
HiLo mast		○	○
Mast protective grille		●	●
Protective mast screen made from polycarbonate		○	○
Tyres	Load rollers, polyurethane, single	●	●
	Load rollers, polyurethane, tandem	○	○
	Load rollers, polyurethane, tandem, lubricated	○	○
	Drive wheel, polyurethane	●	●
	Drive wheel, polyurethane, profiled	○	○
	Drive wheel, polyurethane, soft	○	○
	Drive wheel, solid rubber	○	○
	Drive wheel, solid rubber, profiled	○	○
Safety	Automatic counterbalancing	○	○
	Access authorisation (key)	●	●
	Access authorisation (digicode)	○	○
	FleetManager access authorisation (digicode)	○	○
	FleetManager access authorisation (STILL chip/customer card/customer chip)	○	○
	FleetManager: Shock detection	○	○
	Curve Speed Control: Speed reduction when driving around corners	●	●
	Speed reduction based on mast height	●	●
	Speed limited to 8 km/h	○	○
	Load backrest	○	○
Battery	Overhead guard	—	●
	Lateral battery change with roller conveyor	○	●
	Battery compartment for battery up to 375 Ah	●	●
	Battery compartment for battery up to 500 Ah	○	○
	Battery compartment for battery up to 620 Ah	—	○
205 Ah Li-Ion battery	○	○	
410 Ah Li-Ion battery	○	○	

● Standard ○ Optional — Not available



STILL GmbH
Berzeliusstr. 10
22113 Hamburg
Germany
Tel.: +49 40 73 39 20 00
Fax: +49 40 73 39 20 01
info@still.de

For further information please visit

www.still.eu



Gemini Equipment And Rentals Pvt. Ltd.

1706-1709, The Corporate Park 17th Floor Plot No-14-15
Vashi Navi Mumbai -400705, India.
Email id : info@gear-india.com | Contact No: +918451934343 |
Website: www.gear-india.com

STILL is certified in the following areas: Quality management, occupational safety, environmental protection and energy management.



ISO 9001:2015
ISO 14001:2015
OHSAS 18001:2007

OXV EN 12/20 Subject to technical modifications.

first in intralogistics