

# FXH 33 Technical Data

## Rider Seated Low Lift Pallet Truck

---

FXH 33

---



# FXH 33 Rider Seated Low Lift Pallet Truck

## Top Performance in Record Time

This specification sheet, which conforms to VDI guideline 2198, provides the technical values for the standard equipment only. Different tyres, other masts, the use of accessories, etc. may result in other values.



Features	1.1	Manufacturer			STILL	
	1.2	Manufacturer's type designation			<b>FXH 33</b>	
	1.3	Drive			Electric	
	1.4	Operation			Rider seated	
	1.5	Nominal load capacity		Q	kg	3300
	1.6	Load centre		c	mm	1800
	1.8	Load distance	lowered/raised	$x_1/x_2$	mm	2634/2528
	1.9	Wheel base	lowered/raised	y	mm	3700/3595
	Weights	2.1	Service weight (incl. battery)			kg
2.2		Axle load, laden	drive end/load end		kg	3440/3420
2.3		Axle load, unladen	drive end/load end		kg	2790/770
Wheels/chassis	3.1	Tyres				Vulkollan
	3.2	Tyre size	drive end		mm	Ø 360 x 130
	3.3	Tyre size	load end		mm	Ø 90 x 95
	3.5	Number of wheels (x = driven)	drive end/load end			2 x/4
	3.6	Track width	drive end/load end	$b_{10}/b_{11}$	mm	370/562
	Dimensions	4.4	Lift		$h_3$	mm
4.8		Seat height		$h_7$	mm	1474
4.15		Fork height, lowered		$h_{13}$	mm	91
4.19		Total length		$l_1$	mm	4896
4.20		Length including fork backs		$l_2$	mm	1308
4.21		Total width		$b_1$	mm	1000
4.22		Fork dimensions		s/e/l	mm	70/200/3590
4.25		Overall fork width		$b_5$	mm	571
4.32		Ground clearance, centre of wheel base		$m_2$	mm	20
4.34.1		Working aisle width for pallet 800 x 1200 lengthways	raised	$A_{st}$	mm	5289
4.35		Turning radius		$W_a$	mm	3944
Performance	5.1	Driving speed	laden/unladen		km/h	20/20
	5.1.1	Driving speed backwards	laden/unladen		km/h	20/20
	5.2	Lifting speed	laden/unladen		m/s	0.04/0.05
	5.3	Lowering speed	laden/unladen		m/s	0.05/0.04
	5.8	Maximum gradeability, forks raised	laden/unladen		%	8/10
	5.9	Acceleration speed (to 10 m)	laden/unladen		s	4.1
Electric engine	6.1	Drive motor, rating S2 = 60 min			kW	2 x 6.5
	6.2	Lift motor, rating at S3			kW	2
	6.4	Battery voltage/rated capacity $K_s$			V/Ah	48/930
	6.5	Battery weight ±5% (depending on manufacturer)			kg	1000
	6.6	Energieverbrauch nach DIN EN 16796			kWh/h	0.915
	Misc.	8.1	Transmission control			
10.7		Noise level (at operator's ear)			dB(A)	<70

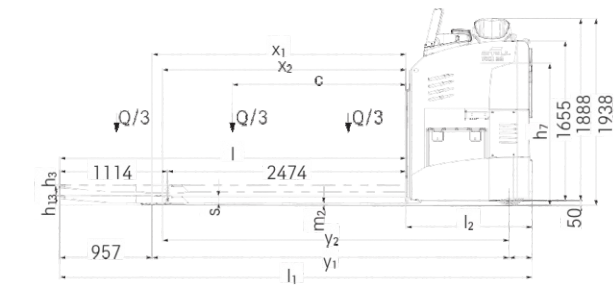

Side view

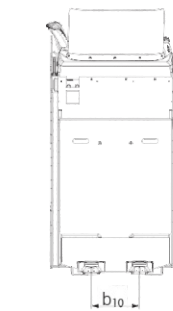

Front view

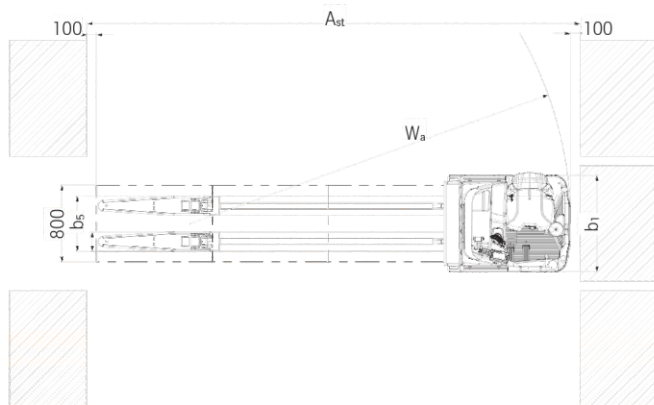

Top view

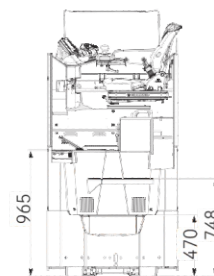

Rear view



Height-adjustable foot plate that adapts to all body sizes for ergonomic working conditions



Easy positioning of optional data terminal and other accessories thanks to integrated accessory rails



Ultimate comfort thanks to cushioned driver's seat and generous leg room



High-precision handling of all functions via joystick and user-friendly operator guidance on the display menu



Easy to manoeuvre even in the most confined spaces thanks to compact chassis contour

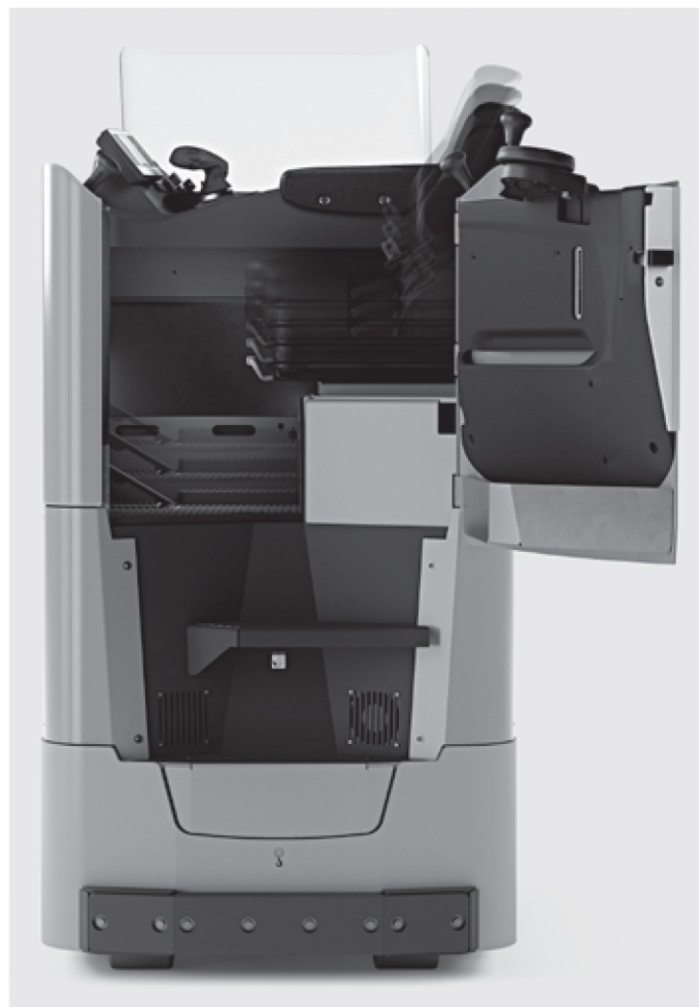

Operator can step on to and off the truck easily and safely thanks to low steps





Effective goods handling due to simultaneous transport of three pallets (3.3 t)

Fast transport of goods even over long distances thanks to travel speeds of up to 20 km/h

Optimal driver's seat ergonomics and visibility of the fork tips thanks to high seat position

Precise, safe lifting and lowering of load due to proportional valve technology



The FXH 33 is the transport locomotive among the STILL low lift pallet trucks. Other models quickly reach their limits in retail and industry – the powerful FXH 33, on the other hand, is completely in its element. Its rounded forks can lift up to three pallets at the same time. Owing to its lifting capacity of up to 3.3 tonnes, which is enormous for its class, the compact powerhouse can handle even the most heavy-duty applications. Coupled with a driving speed of up to 20 km/h, the FXH 33 achieves an outstanding handling capacity. Its exceptional performance is due to its two powerful rotary current drive motors, each with 6.5 kW. The battery is also a strong performer: with up to 930 Ah, it effortlessly masters any heavy-duty operations.

In order to make the operator's work as pleasant as possible, the FXH 33 has a range of impressive features. The brand-new colour display provides information about the battery status, driving speed, kilometres travelled, date and time. The display brightness automatically adjusts to the environment. While the joystick and the electric steering help with precise manoeuvring, the high seat position ensures a clear view of the goods transport. The cushioned driver's seat and the height-adjustable foot plate guarantee an ergonomically optimised driving experience, regardless of the operator's stature. Various systems – including Curve Speed Control, shunting and STILL Safety Light – also ensure maximum safety in the workplace.

## The 'Simply Efficient' factors: Performance attributes as a measure of economic efficiency



### Simply easy

- Easy to manoeuvre even in the most confined spaces due to compact chassis contour
- Exceptional handling performance thanks to optimal visibility of the fork tips
- Rounded fork tips enable fast and secure pallet lifting
- Precise goods handling thanks to fully electric 360° steering
- Intuitive operation of all functions via joystick



### Simply powerful

- Effective goods handling at up to 20 km/h and a lifting capacity of up to 3,300 kg
- Powerful movement thanks to two reliable AC drive motors (48 V)
- Sufficient energy for multi-shift operation thanks to high battery capacity of up to 930 Ah
- Short charge cycles through optional lithium-ion technology
- Precise, safe lifting and lowering using proportional valve technology



### Simply safe

- Ergonomic and safe access via generously sized steps and handhold
- Automatic speed adjustment to the steering angle keeps goods securely in place when cornering
- Sensitive braking along with energy recovery owing to the regenerative braking system

- Optimal safety in the event of a collision thanks to optional impact protection integrated at the drive end
- Visibility for other warehouse employees thanks to blue point of light projected by optional STILL Safety Light / STILL Safety Light 4Plus



### Simply flexible

- Superior comfort thanks to cushioned driver's seat, generous leg room and a range of storage options
- Ergonomic conditions for all body sizes thanks to optional electric height-adjustable foot plate
- Always ready for use with fast, lateral battery change (optional)



### Simply connected

- Clear overview of all relevant information via optional STILL neXXt fleet tool
- Shock detection, access protection against unauthorised third parties and cost optimisation with the optional STILL FleetManager 4.x
- Optimal goods flow thanks to the optional MMS preparation for straightforward integration into the material flow management system
- Easy service analysis and parametrisation of settings via CAN bus interface

# FXH 33 Rider Seated Low Lift Pallet Truck

## Equipment Variants



	FXH 33	
Driver's seat	Comfort driver's seat with hydraulic cushioning and weight and length adjustment	●
	Air-sprung comfort driver's seat	○
	Driver's seat with heating system or leatherette upholstery	○
	Arm rest to the left of the driver's seat	○
	Height-adjustable foot plate	●
	Height-adjustable foot plate, electric	○
	Electric foot heating with thermostat regulation	○
	Joystick for raising/lowering, direction pre-selection and horn	●
	Driver can select from three driver profiles	●
	Easy-to-read display showing active operating states, automatic brightness regulation	●
	Integrated storage options and cup holder	●
	DIN A4 writing surface with clip; optional extra: reading lamp mounted vertically on a profile rail	○
Steering	Fully electric 360° steering	●
	Fully electric steering with reverse function	○
	Redundant steering safety system	●
Drives	Maintenance-free, fully enclosed drive units	●
	Curve Speed Control: speed reduction when driving around corners	●
	Individual parametrisation options	●
	Electric stroke shut-off	●
	Proportional valve technology for especially sensitive lifting	●
Brake	Good service accessibility, easy diagnosis via central diagnostic interface	●
	Electromagnetic brake system	●
	Energy recovery through regenerative braking	●
Battery	Electromagnetic disc brake as parking brake and emergency stop	●
	Lateral battery change with electric forklift truck	●
Additional equipment	Battery compartment for batteries up to 930 Ah	●
	Various fork lengths	○
	Dirt guards in front of and behind the forklift castors	○
	Safety belt on the driver's seat	●
	Warning device STILL Safety Light/STILL Safety Light 4Plus	○
	LED headlights	○
	Electrical preparation for data terminal	○
	Power supply 12-48 V	○
	Lateral accessory rails for attachments	○
	Wind shield on three sides, open towards the forks	○
	Wind shield towards the forks	○
	Shunting (creep speed) for non-activated seat contact switches	○
	Individually adjustable driving speeds	○
	Drive-end impact protection	○
	PIN code access, keyless, with button	○
	FleetManager: access authorisation, shock detection, reports	○
	FleetManager: data transfer via Bluetooth or GPRS	○
	Access authorisation via chip or card	○
	Acoustic warning signal (Digisound)	○
	USB port for charging small electrical devices	○

● Standard ○ Optional — Not available



STILL GmbH  
Berzeliusstr. 10  
22113 Hamburg  
Germany

Tel.: +49 40 73 39 20 00

Fax: +49 40 73 39 20 01

info@still.de

**For further information please visit**

**www.still.eu**



**Gemini Equipment And Rentals Pvt. Ltd.**

1706-1709, The Corporate Park 17th Floor Plot No-14-15  
Vashi Navi Mumbai -400705, India.

Email id : info@gear-india.com | Contact No: +918451934343 |  
Website: www.gear-india.com

STILL is certified in the following  
areas: Quality management,  
occupational safety, environmental  
protection and energy management.



**first in intralogistics**