

1-2.5 t
G series AC Electric
Forklift Truck



1-2.5 t G series AC Electric Forklift Truck



Excellent Visibility

- > Compact structure of mast and driver's view 6% improved.
- > Steering handwheel with 300mm diameter and right installation of meter effectively increase the front view.
- > Large arc shape of the overhead guard and grid tray with proper angle increase operator's upward view.

Better Stability & More Safety

- > New type drive axle and small front overhang design. Longitudinal Stability of the forklift increases by 4.9%.
- > High installation of rear axle increasing transversal stability 2.1%.
- > The space above driver's head is 50mm increased through increasing overhead guard's height and decreasing the seat's height.
- > The space around the driver's foot and operating safety are increased through moving the tilting cylinder to be under the floor board.
- > Multi speed selection function satisfies different working conditions and environment;
- > Standard configuration of warning light and brake automatic warning function improve whole truck's safety.
- > Battery side-extraction function satisfies different customers' needs (optional).
- > Automatic decelerating while steering improves safety (optional).
- > Special side plate and top cover structure is easy for assembly and disassembly.



High Performance & Energy Saving

- > Lifting performance increases by 21%.
- > Climbing and driving performance increase by 20% and 7%.
- > The maximum turning radius is 2020mm, good performance of driving.
- > The minimum turning radius is 1800mm(1-1.8t), 2000mm(2t) and 2020mm(2.5t), good performance of driving.
- > Travelling saves more than 10% energy.
- > LED signal light saves more than 80% energy.
- > Battery cruising ability prolongs about 30 minutes.

Comfortable Operating & Lower Noise

- > Comfortable operating is achieved through moving the steering unit up and 190mm increased operating space around driver's foot.
- > Rear handle with horn function contributes to stable sitting pose when travelling backward and driving comfort and safety.
- > Mast buffer, rear axle buffer and rear extension type valve operation knob increase operating comfort effectively.
- > Ratchet type hand brake facilitates comfort driving.
- > Big getting on and off handle fits different figure size.
- > Ear noise reduces 1 db.



Option battery side pulling

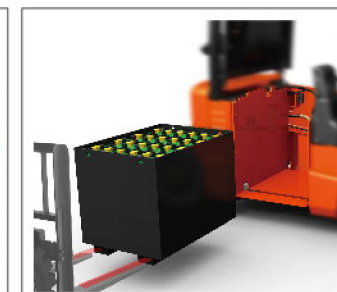

Option battery side loading



1-2.5t G series AC Electric Forklift Truck



Manufacturer's Data and Design Characteristics

character			HELI									
1.01	manufacturer											
1.02	model		CPD10	CPD15	CPD18	CPD10	CPD15	CPD18	CPD20	CPD25	CPD20	CPD25
1.03	configuration number		GC1/GC2(P)	GC1/GC2(P)	GC1/GC2(P)	GD1/GD2/GD3(P)	GD1/GD2/GD3(P)	GD1/GD2/GD3(P)	GC1/GC2(P)	GC1/GC2(P)	GD1/GD2/GD3(P)	GD1/GD2/GD3(P)
1.04	rated capacity	Q kg	1000	1500	1750	1000	1500	1750	2000	2500	2000	2500
1.05	load center distance	c mm	500	500	500	500	500	500	500	500	500	500
1.06	power mode		Battery	Battery	Battery	Battery	Battery	Battery	Battery	Battery	Battery	Battery
1.07	driving mode		Seated	Seated	Seated	Seated	Seated	Seated	Seated	Seated	Seated	Seated
1.08	wheel base	L1 mm	1380	1380	1380	1380	1380	1380	1550	1550	1550	1550
tyre												
2.01	tyre type		Pneumatic	Pneumatic	SE/Pneumatic	Pneumatic	Pneumatic	SE/Pneumatic	Pneumatic	Pneumatic	Pneumatic	Pneumatic
2.02	wheel number(front/rear)		2/2	2/2	2/2	2/2	2/2	2/2	2/2	2/2	2/2	2/2
2.03	front wheel base	W3 mm	910	910	910	910	910	910	960	960	960	960
2.04	rear wheel base	W2 mm	920	920	920	920	920	920	950	950	950	950
2.05	tyre (front)		6.00-9-10PR	6.00-9-10PR	6.00-9	6.00-9-10PR	6.00-9-10PR	6.00-9	23 x 9-10-16PR	23 x 9-10-16PR	23 x 9-10-16PR	23 x 9-10-16PR
2.06	tyre(rear)		16 x 6-8-10PR	16 x 6-8-10PR	16 x 6-8-10PR	16 x 6-8-10PR	16 x 6-8-10PR	16 x 6-8-10PR	18 x 7-8-14PR	18 x 7-8-14PR	18 x 7-8-14PR	18 x 7-8-14PR
size												
3.01	front overhang	L2 mm	390	390	390	390	390	390	434	434	434	434
3.02	mast tilt angle , front/rear	α/β °	6/8	6/8	6/8	6/8	6/8	6/8	6/8	6/8	6/8	6/8
3.03	height with mast retraction	H1 mm	1985	1985	1985	1985	1985	1985	1995	1995	1995	1995
3.04	free lifting height	H3 mm	145	145	145	145	145	145	145	145	145	145
3.05	Max. lifting height	H mm	3000	3000	3000	3000	3000	3000	3000	3000	3000	3000
3.06	Max. height under working condition	H2 mm	4030	4030	4030	4030	4030	4030	4042	4042	4042	4042
3.07	overhead guard height	H4 mm	2130	2130	2130	2130	2130	2130	2150	2150	2150	2150
3.08	fork size:thickness×width×length	T/W/L4 mm	32 × 100 × 770	35 × 100 × 920	35 × 100 × 920	32 × 100 × 770	35 × 100 × 920	35 × 100 × 920	35 × 100 × 920	40 × 122 × 920	40 × 122 × 1070	40 × 122 × 920
3.09	fork arm carrier, DIN standard		2A	2A	2A	2A	2A	2A	2A	2A	2A	2A
3.10	truck body length (fork excluded)	L' mm	2070	2070	2070	2070	2070	2070	2285	2295	2285	2295
3.11	truck body width	W1 mm	1086	1086	1086	1086	1086	1086	1185	1185	1185	1185
3.12	turning radius	r mm	1750	1750	1750	1750	1750	1750	2000	2020	2000	2020
3.13	clearance between mast and ground	H5 mm	90	90	80	90	90	80	110	110	110	110
3.14	clearance between wheel base center and ground (loaded)	H6 mm	95	95	90	95	95	90	115	115	115	115
3.15	right angle stacking aisle width (pallet1000x1000mm, clearance 200mm)	Ast mm	3340	3340	3340	3340	3340	3340	3635	3655	3635	3655
3.16	right angle stacking aisle width (pallet1200x1200mm, clearance 200mm)	Ast mm	3540	3540	3540	3540	3540	3540	3835	3855	3835	3855
3.17	Lateral Fork Adjustment (Outside of Forks) Max./Min.	W5 mm	960/200	960/200	960/200	960/200	960/200	960/200	1030/244	1030/244	1030/244	1030/244
performance												
4.01	travelling speed: loaded/unloaded	km/h	15/16	15/16	15/16	15/16	15/16	15/16	14.5/15	14.5/15	14.5/15	14.5/15
4.02	lifting speed: loaded/unloaded	m/s	0.29/0.45	0.27/0.45	0.28/0.53	0.41/0.60	0.40/0.60	0.38/0.60	0.28/0.49	0.26/0.49	0.35/0.51	0.33/0.51
4.03	lowering speed: loaded/unloaded	m/s	0.50/0.40	0.50/0.40	0.50/0.40	0.50/0.40	0.50/0.40	0.50/0.40	0.49/0.41	0.49/0.41	0.49/0.41	0.49/0.41
4.04	gradeability (loaded)	%	24	22	20	24	22	20	22	20	22	20
4.05	Max. traction force (loaded)	N	10000	10000	10000	10000	10000	10000	16000	16500	16000	16500
4.06	acceleration time (10m) loaded/unloaded	s	5.0/4.4	5.2/4.5	5.2/4.6	5.0/4.4	5.2/4.5	5.2/4.6	4.6/4.4	4.8/4.6	4.6/4.4	4.8/4.6
weight												
5.01	total weight (with /without battery)	kg	2920/2240	3030/2240	3220/2430	2920/2240	3030/2240	3220/2430	4060/2960	4250/3150	4160/2960	4350/3150
5.02	axle load: unloaded, front/rear	kg	1508/1412	1505/1525	1493/1727	1508/1412	1505/1525	1493/1727	1860/2200	2000/2250	1900/2260	2000/2350
5.03	axle load: loaded, front/rear	kg	3150/770	4005/525	4372/598	3150/770	4005/525	4372/598	5270/790	5930/820	5300/860	5950/900
battery												
6.01	battery voltage/capacity Ks	V/Ah	48/400(max600)	48/480(max600)	48/480(max600)	48/400(max600)	48/480(max600)	48/480(max600)	48/600(max800)	48/600(max800)	48/700(max800)	48/700(max800)
6.02	battery weight	kg	680(600-1000)	790(720-1000)	790(720-1000)	680(600-1000)	790(720-1000)	790(720-1000)	1000(950-1300)	1000(950-1300)	1100(950-1300)	1100(950-1300)
6.03	battery, DIN standard		43531A	43531A	43531A	43531A	43531A	43531A	43531A	43531A	43531A	43531A
motor and controller												
7.01	drive motor power-60 minutes	kW	8.2	8.2	8.2	8.2	8.2	8.2	11.5	11.5	11.5	11.5
7.02	lifting motor power-S3 15%	kW	7.5	7.5	8.6	10.6	10.6	10.6	10.5	10.5	15	15
7.03	drive motor controlling mode		MOSFET/AC	MOSFET/AC	MOSFET/AC	MOSFET/AC	MOSFET/AC	MOSFET/AC	MOSFET/AC	MOSFET/AC	MOSFET/AC	MOSFET/AC
7.04	lifting motor controlling mode		MOSFET/DC	MOSFET/DC	MOSFET/DC	MOSFET/AC	MOSFET/AC	MOSFET/AC	MOSFET/DC	MOSFET/DC	MOSFET/AC	MOSFET/AC
7.05	service brake/parking brake		Hydraulic/Mechanical	Hydraulic/Mechanical	Hydraulic/Mechanical	Hydraulic/Mechanical	Hydraulic/Mechanical	Hydraulic/Mechanical	Hydraulic/Mechanical	Hydraulic/Mechanical	Hydraulic/Mechanical	Hydraulic/Mechanical
7.06	hydraulic system working pressure	Mpa	14.5	14.5	17.5	14.5	14.5	17.5	17.5	17.5	17.5	17.5

NOTE: *Detailed information about battery, please contact our salesman or engineer. 1、① Battery capacity 600Ah for battery side extraction."P" battery side extraction (side pulling or side loading),side pulling for standard. 2、1: For configuration number, CURTIS Controller; 2: ZAPI Controller; 3: Inmotion Controller.

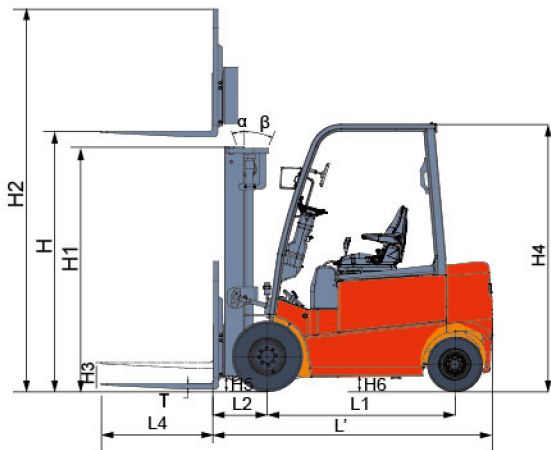

Ast: Right angle stacking aisle width

- a: Clearance
- b: Load Length

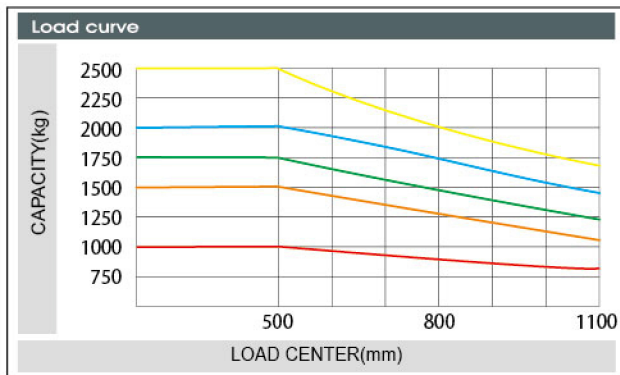
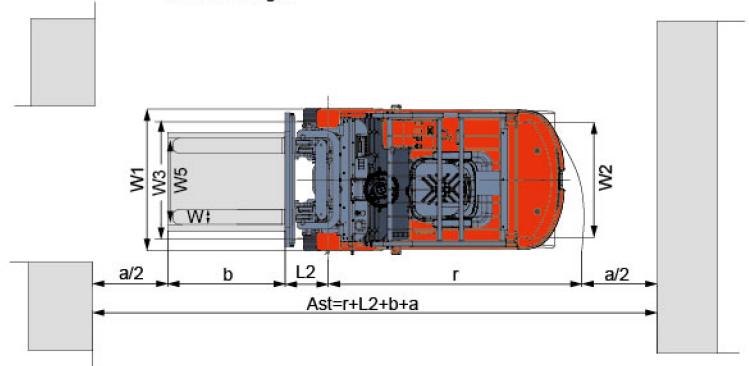

- CPD10
- CPD15
- CPD18
- CPD20
- CPD25

Note: The vertical axis stands for load capacity and the horizontal axis stands for load center which is calculated from the front surface of the forks to the gravity of the standard load. the standard load means a cubic with 1000mm edge length. When mast is tilted forward, using non-standard forks or loading large goods, the load capacity will be reduced. The load capacity of standard mast at different load center can be known from this load chart.

WIDE VIEW MAST														
mast model	Max. lifting height mm	load capacity (load center 500mm) (kg)					mast overall height (fork to the ground) (mm)		service weight (kg)					mast tilt angle (°) α/β
		1t	1.5t	1.8t	2t	2.5t	1-1.8t	2-2.5t	1t	1.5t	1.8t	2t	2.5t	
M200	2000	1000	1500	1750	2000	2500	1485	1495	2857	2967	3157	3970	4160	6/8
M250	2500	1000	1500	1750	2000	2500	1735	1745	2888	2998	3188	4014	4204	6/8
M300	3000	1000	1500	1750	2000	2500	1985	1995	2920	3030	3220	4060	4250	6/8
M330	3300	1000	1500	1750	2000	2500	2135	2145	2940	3050	3240	4086	4276	6/8
M350	3500	1000	1500	1750	2000	2500	2235	2245	2953	3063	3253	4104	4294	6/8
M370	3700	1000	1500	1750	2000	2500	2335	2345	2965	3075	3265	4122	4312	6/8
M400	4000	1000	1500	1750	2000	2500	2535	2545	3014	3124	3314	4182	4372	6/5
M425	4250	1000	1500	1750	2000	2500	2660	2670	3030	3140	3330	4205	4395	6/5
M450	4500	1000	1400	1600	1900	2300	2785	2795	3046	3156	3346	4228	4418	6/5
M500	5000	1000	1200	1350	1800	1950 *2050	3035	3045	3079	3189	3379	4273	4463	6/5 *6/5
M550	5500	900	1100	1200 *1500	1400	1550 *1950	3335	3345	3140	3250	3440	4351	4541	3/3 *6/5
M600	6000	800 *1000	800 *1150	850 *1400	950 *1500	1100 *1800	3585	3595	3172	3282	3472	4397	4587	3/3 *6/5

NOTE: (1)* refers to rated capacity with widen tires;

WIDE VIEW FULL FREE 2-STAGE MAST

mast model	Max. lifting height (mm)	load capacity (load center 500mm) (kg)					mast overall height (mm)		free lifting height (with backrest)(mm)		service weight (kg)					mast tilt angle (°) α/β
		1t	1.5t	1.8t	2t	2.5t	1-1.8t	2-2.5t	1-1.8t	2-2.5t	1t	1.5t	1.8t	2t	2.5t	
ZM200	2000	1000	1500	1750	2000	2500	1485	1495	478	447	2900	3010	3200	3980	4170	6/8
ZM250	2500	1000	1500	1750	2000	2500	1735	1745	728	697	2932	3042	3232	4026	4216	6/8
ZM300	3000	1000	1500	1750	2000	2500	1985	1995	978	947	2966	3076	3266	4075	4265	6/8
ZM330	3300	1000	1500	1750	2000	2500	2135	2145	1128	1097	2988	3098	3288	4104	4294	6/8
ZM350	3500	1000	1500	1750	2000	2500	2235	2245	1228	1197	3003	3113	3303	4123	4313	6/8
ZM370	3700	1000	1500	1750	2000	2500	2335	2345	1328	1297	3015	3125	3315	4142	4332	6/8
ZM400	4000	1000	1500	1750	2000	2500	2535	2545	1528	1497	3063	3173	3363	4205	4395	6/5
ZM425	4250	1000	1500	1750	2000	2500	2660	2670	1653	1622	3082	3192	3382	4229	4419	6/5
ZM450	4500	1000	1400	1600	1900	2300	2785	2795	1778	1747	3101	3211	3401	4254	4444	6/5
ZM500	5000	1000	1200	1350	1800	1950 *2050	3035	3045	2028	1997	3135	3245	3435	4302	4492	6/5 *6/5
ZM550	5500	900	1100	1200 *1500	1400	1550 *1950	3335	3345	2328	2297	3196	3306	3496	4384	4574	3/3 *6/5
ZM600	6000	800 *1000	800 *1150	850 *1400	950 *1500	1100 *1800	3585	3595	2578	2547	3230	3340	3530	4433	4623	3/3 *6/5

NOTE: (1)* refers to rated capacity with wider tires;
 (2) 1-1.8T: free lifted height 365mm increased without backrest;
 (3) 2-2.5T: free lifted height 397mm increased without backrest;

WIDE VIEW FULL FREE 3-STAGE MAST

mast model	Max. lifting height (mm)	load capacity (load center 500mm) (kg)					mast overall height (mm)		free lifting height (with backrest)(mm)		service weight (kg)					mast tilt angle (°) α/β
		1t	1.5t	1.8t	2t	2.5t	1-1.8t	2-2.5t	1-1.8t	2-2.5t	1t	1.5t	1.8t	2t	2.5t	
ZSM360	3600	1000	1500	1750	2000	2500	1780	1795	770	774	3014	3124	3314	4217	4407	6/8
ZSM400	4000	1000	1500	1750	2000	2500	1915	1920	905	900	3038	3148	3338	4252	4442	6/5
ZSM435	4350	1000	1450	1650	2000	2450	2030	2045	1020	1024	3062	3172	3362	4287	4477	6/5
ZSM450	4500	1000	1400	1600	2000	2300	2080	2095	1070	1074	3073	3183	3373	4301	4491	6/5
ZSM470	4700	1000	1350	1550	2000	2200	2150	2160	1140	1140	3089	3199	3389	4319	4509	6/5
ZSM480	4800	1000	1300	1500	1900	2050	2180	2195	1170	1174	3097	3207	3397	4329	4519	6/5
ZSM500	5000	1000	1200	1300	1800	1950 *2050	2280	2295	1270	1274	3118	3228	3418	4357	4547	6/5 *6/5
ZSM540	5400	1000	1000	1050 *1400	1400	1550 *1950	2405	2420	1395	1400	3143	3253	3443	4399	4589	3/3 *6/5
ZSM600	6000	700 *1000	750 *1100	750 *1300	950 *1500	1100 *1800	2630	2645	1620	1624	3215	3325	3515	4462	4652	3/3 *6/5
ZSM650	6500	550 *1000	600 *1050	600 *1100	700 *1400	800 *1600	2830	2835	1810	1814	3253	3363	3553	4495	4685	3/3 *3/5
ZSM700	7000	*900	*950	*950	300 *1100	400 *1200	3015	3105	2005	2084	3292	3402	3592	4550	4740	3/3 *3/5

NOTE: (1)* refers to rated capacity with wider tires;
 (2) 1-1.8T: free lifted height 480mm increased without backrest;
 (3) 1-1.8T: free lifted height 400mm increased without backrest when assembled with pulley block;
 (4) 2-2.5T: free lifted height 451mm increased without backrest;
 (5) 2-2.5T: free lifted height 401mm increased without backrest when assembled with pulley block.

Renewable energy technologies

With the use of the excellent load-sensing steering system and AC controlling renewable energy technologies, the forklift is more energy-saving and the working hour of the battery is extended by 15%.

↑15%
 THE PERFORMANCE OF
 BATTERY INCREASES

The reliable special instrument gives a complete display of the key information, like operating status, fault detection, etc. It ensures the operator predominate the vehicle status more intuitive and convenient.

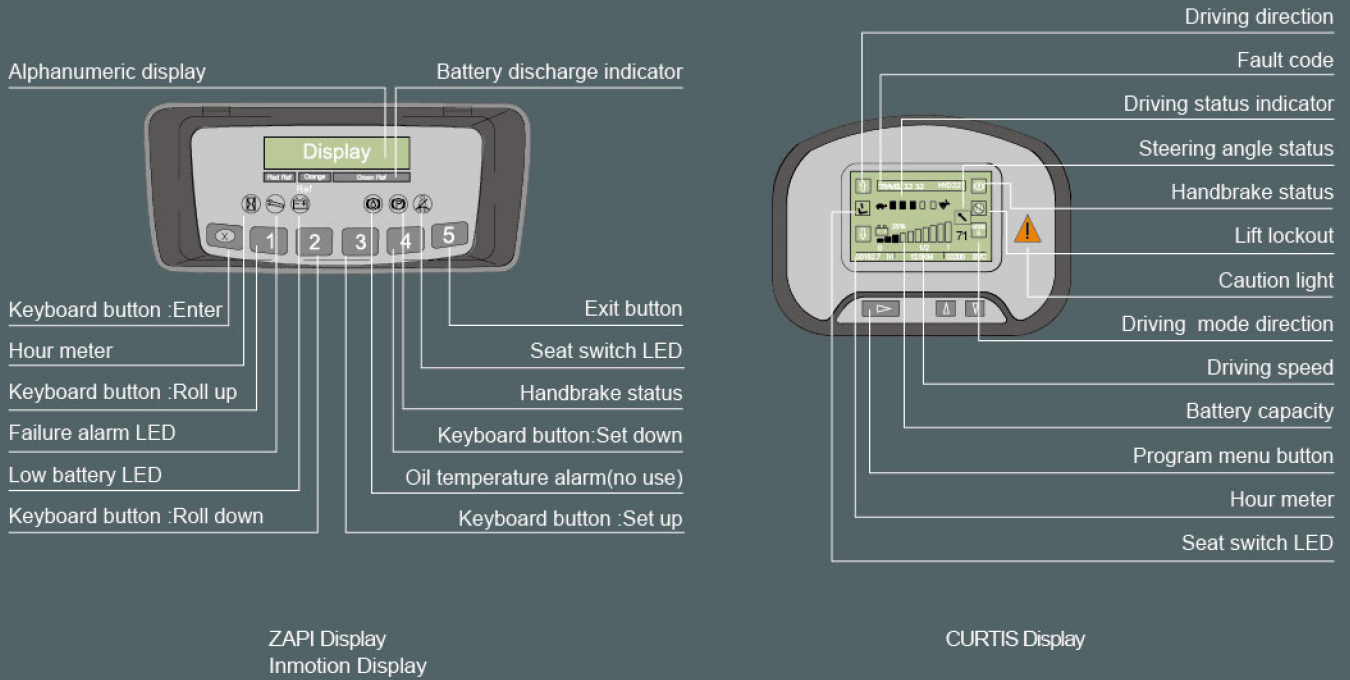

Standard configuration

- Wide view standard mast
- Class II/III standard carriage
- Load backrest
- Control valve
- Battery
- Standard seat
- Overhead guard
- Overhead guard rain cover
- Pneumatic tires
- Traction pin
- Driver's tool
- LCD combination instrument
- Head light
- LED signal light
- Rear handle with horn

Optional device

- 3-stage full free mast
- 2-stage full free mast
- Wide carriage
- Long forks
- Fork extension sleeve
- Solid tires
- Widen tires
- Warning light
- Rear working light
- Tilt/steering cylinder boot
- Cab
- Suspension seat
- Customer color
- Coloring tires (white/green)
- Automatic steering slow down device

Attachments

- Side shifter
- Side shifting fork positioner
- Cargo boom
- Lifting hook
- Paper roll clamp
- Bale clamp
- Multifunction clamp
- Load stabilizer
- Push pulls
- Drum clamp
- Rotator
- Carton clamp
- Battery lifting sling

* Details of specifications and equipment are based on information available at time of printing and may change without notice.