



HELI

8.5-10 t

**G series battery powered
counterbalanced Forklift truck
(Lead acid/Lithium)**



High stability and reliability

- Mature and reliable, excellent performance of international core components: wheel-driving unit, AC traction motor, AC pump motor and controller ,etc;
- Lowering height of gravity center by optimizing the quality distribution of the whole vehicle, the load capacity of mast in high-order position is stronger than trucks with the same tonnage.

Active safety

- Active safety protection, actively slowing down and implementing the parking brake after parking when the critical components are out of order;
- System monitoring the brake temperature is too high, the vehicle limits the speed and travels with the tortoise speed;
- Automatic speed limitation while turning;
- Driver presence sensing system;
- Terminal buffer of lifting, other aspects implement active safety protection.

High efficiency and Energy-saving

- Compact body design makes the vehicle having great flexibility, moving freely as one wishes even in a small space;
- Low vehicle weight ensures low energy consumption;
- Energy-saving type hydraulic system with double pump confluence;
- Full hydraulic synchronous steering system ensures more accurate steering control (Optional);
- Power recovery has priority, piecewise superimposed electric-hydraulic braking with energy regeneration (Optional).
- The Lithium battery forklift equipped with 80V/2*200A fast charger.

Intellectualization

- The circulating cooling system based on multi-point temperature intelligent control makes the temperature of each component in the optimum working range;
- The electronic fan with independent hydraulic oil cooling adopts intelligent control to start and stop, achieving the effect of saving energy and reducing noise at the same time.

Comfortable

- Import super silent gear pump and motor damping pad to ensure low noise of vehicle;
- Fully suspension operator's seat.

Convenient maintenance

- Auto water filling (Lead acid battery) ;
- The body equips with independent interlocking vehicle fast charging interface, intelligent control and diagnosis function to ensure charging safety;
- Maintenance free wet braking;
- Within 30s after vehicle shutdown, the reversal of cooling can remove dust, maintenance free;
- The two groups of batteries are symmetrically arranged on the left and right sides, and can be quickly replaced at any time by lateral side shovel;
- The height of electric control warehouse is suitable for maintenance.

Exterior and Vision

- Fire-new exterior design, the body lines are smooth, beautiful and streamlined;
- Super-low height of balance weight without tailstock, which provides the driver with an excellent rear vision field.



HELI smart fleet management system (optional)

- Vehicle positioning
- Remote diagnosis
- Remote monitoring
- Maintenance reminder
- Battery management
- Statistical form
- Vehicle management
- Identification recognition (optional)
- Weight management (optional)
- Collision management (optional)

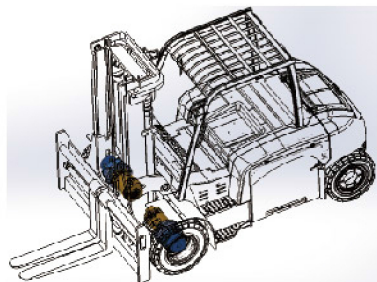

Integrated dual driving system

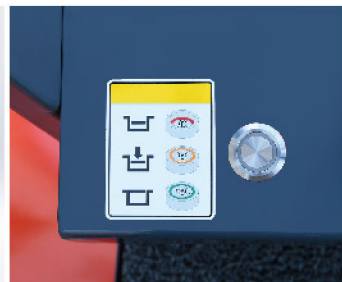

Automatic parking button



Terminal buffer of lifting



Interlocking vehicle fast charging interface



Comfortable height of operation of electric control warehouse and lock-type traction pin

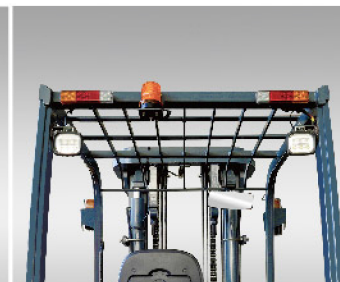

Double rear working lights, revolving beacon

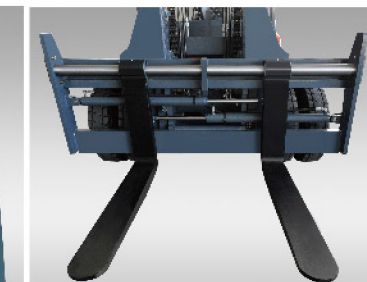

Intergrated fork positioner



Auto water filling

Manufacturer and technical parameters

		HELI								
		CPD85		CPD100		CPD85		CPD100		
1.01	Manufacturer									
1.02	Model	CPD85		CPD100		CPD85		CPD100		
1.03	Configuration number	GA2		GA2 GB2		GA2Li		GA2Li GB2Li		
1.04	Rated capacity	Q(kg)	8500	10000	10000	8500	10000	10000	10000	
1.05	Load center distance	c(mm)	600	600	600 ⁽¹⁾	600	600	600	600 ⁽¹⁾	
1.06	Power mode	Battery				Lithium Battery				
1.07	Driving mode	Seated				Seated				
1.08	Wheel base	L1(mm)	2400	2580		2400	2580			
2.01	Tyre type	Solid type				Solid type				
2.02	Wheel number(front/rear)	4×/2				4×/2				
2.03	Front wheel base	W3/W4(mm)	1636/1524			1636/1524				
2.04	Tyre(front/rear)	8.25-15/250-15				8.25-15/250-15				
3.01	Front overhang	L2(mm)	660				660			
3.02	Mast tilt angle, front/rear	α/β(°)	6/9				6/9			
3.03	Height with mast retraction	H1(mm)	2700	2850	2950	2700	2850	2950		
3.04	Free lifting height	H3(mm)	180				180			
3.05	Max.Lifting height	H(mm)	3000				3000			
3.06	Overhead guard height	H4(mm)	2445				2445			
3.07	Overhead guard clearance(from face of seat)	H7(mm)	1024				1024			
3.08	Max.Height under working condition	H2(mm)	4226	4360	4510	4226	4360	4510		
3.09	Traction pin center height	H9(mm)	687	677		687	677			
3.10	Backrest height(calculated from the fork surface)	H13(mm)	1012				1012			
3.11	fork size:thickness×width×length	T×W×L4(mm)	85×175×1370		85×175×1820		85×175×1370		85×175×1820	
3.12	Truck body length(with forks)	L(mm)	4950	5130	5580	4950	5130	5580		
3.13	Truck body length(without forks)	L'(mm)	3580	3760		3580	3760			
3.14	Truck body width	W2(mm)	2116/1750			2116/1750				
3.15	Turning radius	r(mm)	3140	3320		3140	3320			
3.16	Clearance between mast and ground	H5(mm)	130/150				130/150			
3.17	Clearance between wheel base center and ground (loaded)	H6(mm)	170/180				170/180			
3.18	Right angle stacking aisle width(pallet1000×1200mm across forks, clearance 200mm)	Ast(mm)	5000	5180		5000	5180			
3.19	Right angle stacking aisle width(pallet800×1200mm along forks, clearance 200mm)	Ast(mm)	5200	5380		5200	5380			
3.20	Lateral fork adjustment (outside of fork)(min/max)	W6(mm)	420-2060				420-2060			
4.01	Travelling speed: loaded/unloaded	km/h	14/16	13/15		14/16	13/15			
4.02	Lifting speed: loaded/unloaded	m/s	0.30/0.37	0.245/0.335		0.30/0.37	0.245/0.335			
4.03	Lowering speed:loaded/unloaded	m/s	0.42/0.38			0.42/0.38				
4.04	Gradeability (loaded/unloaded)	%	15/25	15/20		15/25	15/20			
4.05	Max.Traction force(loaded)	kN	35	45		35	45			
4.06	Acceleration time(10m)loaded/unloaded	s	6/5	6/5	6/5	6/5	6/5	6/5		
5.01	Total weight(with/without battery)	kg	12600/9600	13200/9800	14160/10840	11660/10560	12900/11800	14160/13060		
5.02	Axle:unloaded,front/rear	kg	6370/6230	6795/6415	7020/7140	5725/5935	6495/6415	7120/7040		
5.03	Axle:loaded,front/rear	kg	19330/1770	21670/1530	21910/2250	18690/1470	21370/1530	22010/2150		
6.01	Battery voltage/capacity(discharging capacity in 5 hours)	V/Ah	80/1120	80/1240		80/404×2	80/542×2			
6.02	Battery weight	kg	1500×2	1600×2		550×2	550×2			
7.01	Drive motor power(s2- 60min)	kW	AC17.1×2				AC17.1×2			
7.02	Lifting motor power(s3-15%)	kW	AC26.5×2				AC26.5×2			
7.03	braking motor power(s3-15%)	kW	AC 5				AC 5			
7.04	Drive motor controlling mode	MOSFET/AC				MOSFET/AC				
7.05	Lifting motor controlling mode	MOSFET/AC				MOSFET/AC				
7.06	Braking motor controlling mode	MOSFET/AC				MOSFET/AC				
8.01	Service brake	Hydraulic wet brake				Hydraulic wet brake				
8.02	Parking brake	Hydraulic, Electric switch				Hydraulic, Electric switch				
8.03	Hydraulic system working pressure	MPa	20				20			
8.04	Type of drive control	ZAPI				ZAPI				

Note 1: This model is reinforced, and the difference between GA2 and GB2 is that it has the ability of 9 t at the center of 900 load. See the load curve for details.

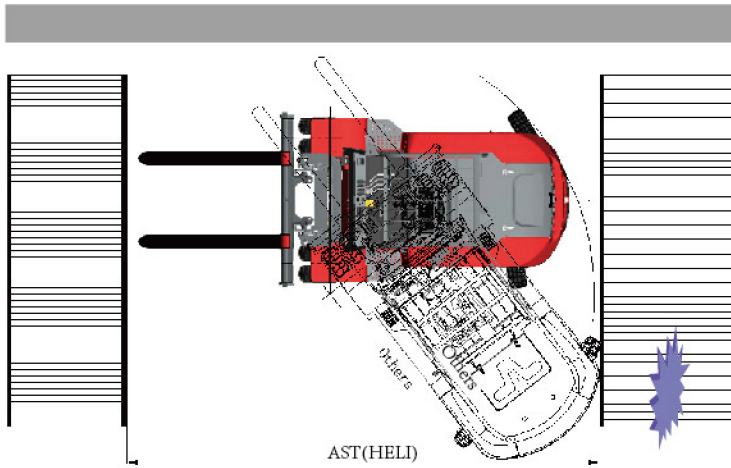

- Right angle stacking aisle width (pallet 1200x1200mm, clearance 200mm)
5380mm(CPD100)
6040mm(CPCD100) (Others)

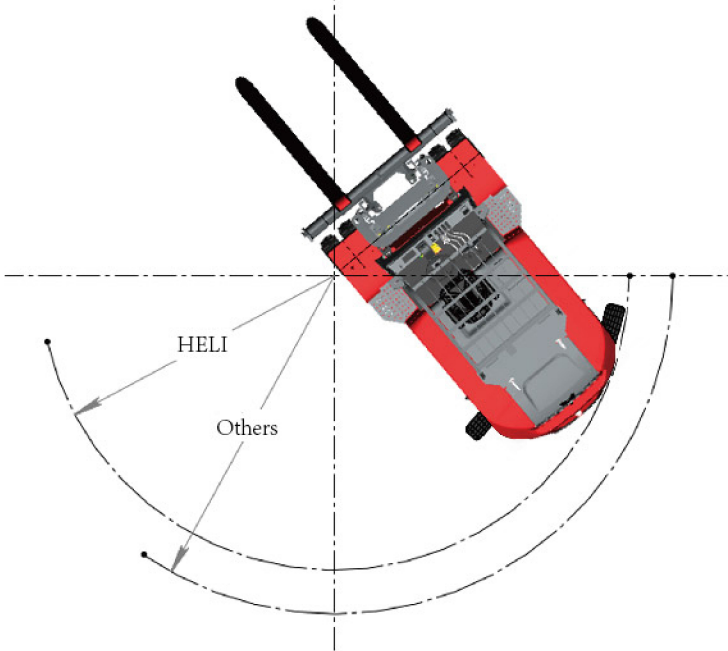

- The compact body design and smaller wheelbase allow the vehicle to sprinkle freely in a narrow space while maintaining the power and speed capable of achieving high productivity.
- truck body length(without forks)
3760mm(CPD100)
4210mm(CPCD100) (Others)
- turning radius
3320mm(CPD100)
3900mm(CPCD100) (Others)

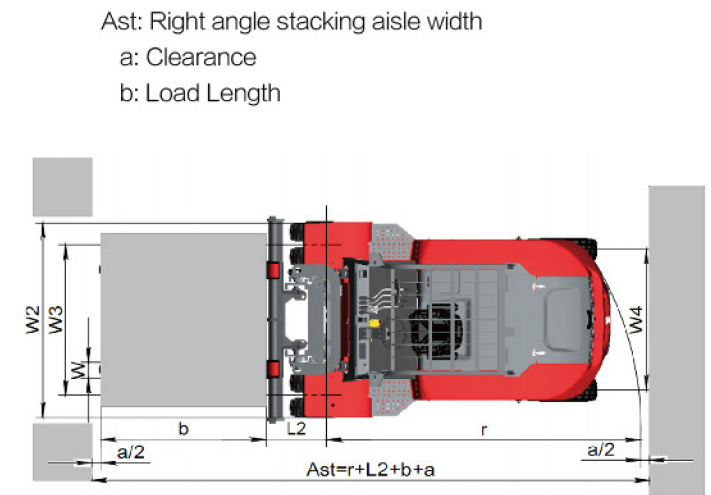
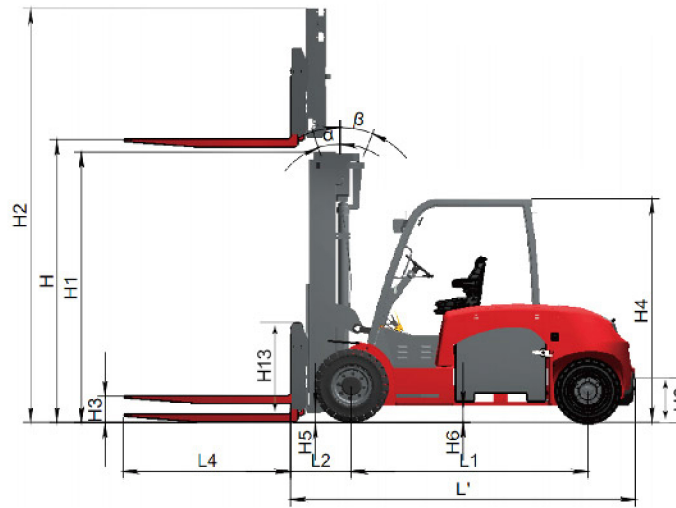

Ast: Right angle stacking aisle width
a: Clearance
b: Load Length

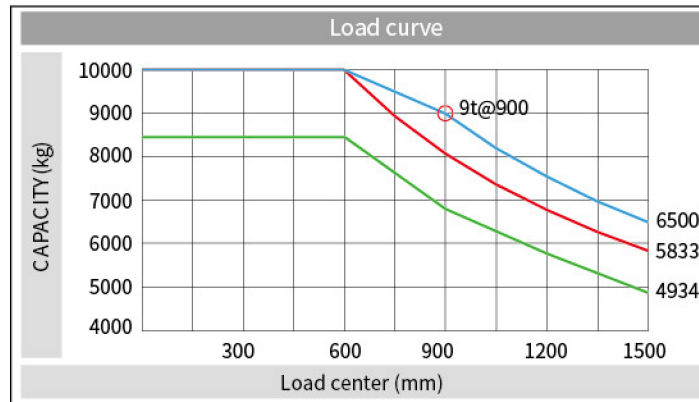

CPD100-GA2
CPD100-GA2Li

CPD100-GB2
CPD100-GB2Li

CPD85-GA2
CPD85-GA2Li

Note: The vertical axis stands for load capacity and the horizontal axis stands for load center which is calculated from the front surface of the forks to the gravity of the standard load. the standard load means a cubic with 1200mm edge length. When mast is tilted forward, using non-standard forks or loading large goods, the load capacity will be reduced. The load capacity of standard mast at different load center can be known from this load chart.

Battery				
model	battery	voltage (V)	Lead acid battery capacity (Ah)	Lithium battery capacity (Ah)
CPD85	standard	80	1120	808
	optional	80	1240	1084
CPD100	standard	80	1240	1084
	optional	80	1400	/
		80	1550	/

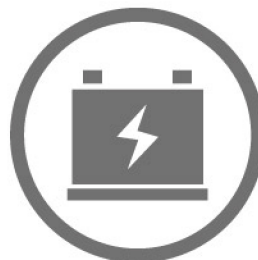

RENEWABLE ENERGY TECHNOLOGIES

With the use of the excellent load-sensing steering system and AC controlling renewable energy technologies, the forklift is more energy-saving and the working hour of the battery is extended by 15%.



15%

8.5-10t WIDE VIEW MAST

Mast model	Max. fork height (mm)	Load capacity (load center 600mm)(Kg)		Mast height, lowered(mm)			Service weight (kg)			门架倾角 Mast tilting angle (°)α / β
		CPD85	CPD100	CPD85	CPD100-GA2	CPD100-GB2	CPD85	CPD100-GA2	CPD100-GB2	
M250	2500	8500	10000	2450	2600	2700	11910	13090	14060	6/9
M270	2700	8500	10000	2550	2700	2800	11970	13120	14090	6/9
M300	3000	8500	10000	2700	2850	2950	12600	13200	14160	6/9
M330	3300	8500	10000	2850	3000	3100	12700	13250	14220	6/9
M350	3500	8500	10000	2950	3100	3200	12840	13290	14260	6/9
M375	3750	8500	10000	3075	3225	3325	12920	13340	14310	6/9
M400	4000	8500	10000	3250	3400	3500	13100	13380	14350	6/9
M425	4250	8500	10000	3375	3525	3625	13250	13450	14420	6/9
M450	4500	8500	10000	3500	3650	3750	13370	13500	14470	6/9
M475	4750	8500	10000	3625	3775	3875	13520	13560	14530	6/6
M500	5000	8500	10000	3750	3900	4000	13620	13600	14570	6/6
M550	5500	8000	9500	4050	4200	4300	13950	13900	14870	3/6
M600	6000	7500	9000	4300	4450	4550	14150	13950	14920	3/6
M650	6500	-	8500	-	4700	4800	-	14000	14970	3/6
M700	7000	-	8000	-	5050	5150	-	14050	15020	3/6

WIDE VIEW FULL FREE 2-STAGE MAST

Mast model	Max. fork height (mm)	Load capacity (load center 600mm)(Kg)		Mast height, lowered(mm)			Free lift (mm)		Service weight (kg)			Mast tilting angle (°)α / β
		CPD85	CPD100	CPD85	CPD100-GA2	CPD100-GB2	CPD85	CPD100	CPD85	CPD100-GA2	CPD100-GB2	
ZM250	2500	8500	10000	2450	2600	2700	1090	1300	11970	13150	14120	6/9
ZM270	2700	8500	10000	2550	2700	2800	1190	1400	12030	13180	14150	6/9
ZM300	3000	8500	10000	2700	2850	2950	1340	1550	12620	13220	14190	6/9
ZM330	3300	8500	10000	2850	3000	3100	1490	1700	12720	13270	14240	6/9
ZM350	3500	8500	10000	2950	3100	3200	1590	1800	12850	13300	14270	6/9
ZM375	3750	8500	10000	3075	3225	3325	1715	1925	12910	13330	14300	6/9
ZM400	4000	8500	10000	3250	3400	3500	1890	2100	13200	13480	14450	6/9
ZM425	4250	8500	10000	3375	3525	3625	2015	2225	13310	13500	14470	6/9
ZM450	4500	8500	10000	3500	3650	3750	2140	2350	13420	13550	14520	6/9
ZM475	4750	8500	10000	3625	3775	3875	2265	2475	13540	13580	14550	6/6
ZM500	5000	8500	10000	3750	3900	4000	2390	2600	13640	13620	14590	6/6
ZM550	5500	8000	9500	4050	4200	4300	2690	2900	13850	13800	14770	3/6
ZM600	6000	7500	9000	4300	4450	4550	2940	3150	14070	13870	14840	3/6

WIDE VIEW FULL FREE 3-STAGE MAST

Mast model	Max. fork height (mm)	Load capacity (load center 600mm)(Kg)		Mast height, lowered(mm)		Free lift (mm)		Service weight (kg)			Mast tilting angle (°)α / β
		CPD85	CPD100	CPD85	CPD100	CPD85	CPD100	CPD85	CPD100-GA2	CPD100-GB2	
ZSM360	3600	7500	9000	2450	2570	1090	1150	13540	13960	14930	6/9
ZSM400	4000	7500	9000	2575	2700	1215	1280	13770	14050	15020	6/9
ZSM435	4350	7500	9000	2700	2820	1340	1400	13940	14130	14800	6/9
ZSM450	4500	7500	9000	2775	2870	1415	1475	14040	14170	15140	6/6
ZSM480	4800	7500	9000	2850	2970	1490	1550	14200	14240	15210	6/6
ZSM500	5000	7500	9000	2950	3035	1590	1615	14310	14290	15260	6/6
ZSM540	5400	7000	8500	3075	3225	1775	1805	14470	14420	15390	3/6
ZSM600	6000	6500	8000	3375	3425	2015	2005	14760	14560	15530	3/6
ZSM650	6500	6000	7500	3600	3590	2240	2170	14880	14680	15650	3/6
ZSM700	7000	5500	7000	3750	3855	2390	2435	15050	14850	15820	3/6
ZSM800	8000	4500	6000	4135	4240	2640	2685	15260	15060	16030	3/6

Reliable special designed instrument

Alphanumeric display

Battery discharge indicator

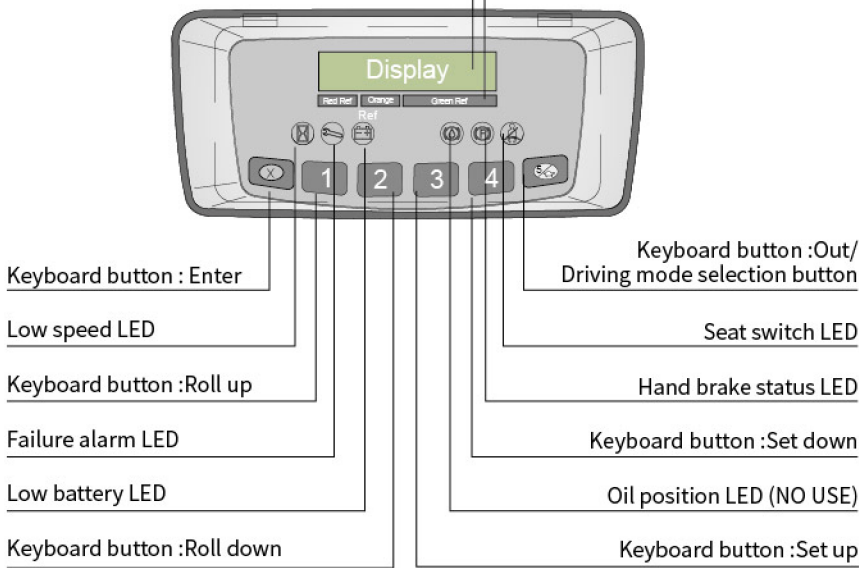

ZAPI Display

- Reliable special meter displays the whole truck's working condition, fault detect and other important information completely which makes the operator master the whole truck condition directly and conveniently.

Standard configuration

- Standard of driver presence sensing system
- Automatic speed limitation while turning
- All solid tire
- Automatic water filling
- Intergrated fork positioner
- Full suspension seat
- Full vehicle led lights
- Double rear working lights
- Rotating beep warning light
- Automatic parking
- Four piece valve, double overload, rubber hose and Pulley block
- Domestic leoch battery
- CPD100-GB2 marking 1820 fork

Optional device

- Synchronous steering
- Electric-hydraulic braking
- Cab
- Windshield (front windshield/window, top windshield/window, rear windshield/window)