

1.5-2 t

**G2 series Three Wheel
AC Electric Forklift Truck**

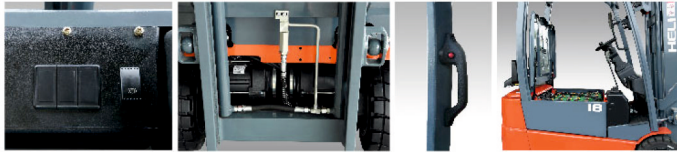

COMFORTABLE



- ✓ Magnetic brake on driving axle, the truck can automatic parking in slope or flat.
- ✓ Rear handle with horn function contributes to stable sitting pose when travelling backward and driving comfort and safety.
- ✓ Automobile type direction switch effectively improve driving comfort level.
- ✓ Sensor operated power steering(option), more comfortable.
- ✓ Side battery as option, easy replacement.
- ✓ Finger switch as option, more speedy operation.

IMPROVED DRIVER'S VIEW



- ✓ Newly designed wide-view mast with special chains enlarges operator's view effectively.
- ✓ Large arc shape of the overhead guard and grid tray with proper angle increase operator's upward view.

SAFETY

- ✓ Better loading capacity at high position.
- ✓ automatic deceleration on curved road, more intelligent and safe.
- ✓ Standard configuration of warning light and drive OPS system improve whole truck's safety.



WORKING EFFICIENCY

- ✓ Small turning radius makes steering flexible and easy.
- ✓ The truck has fast driving and lifting speed, higher working efficiency.
- ✓ Three speed mode, high performance.
- ✓ Larger battery capacity for longer single shift time.



ENERGY EFFICIENCY

- ✓ With optimized hydraulic system, the truck is more energy-efficient and has lower energy consumption.
- ✓ Save more than 80% lighting energy with LED lights.
- ✓ Motor regenerative braking can recycle more electric energy.

MAINTAINABILITY

- ✓ The cover can be disassembled easily, contributes to quick and convenient maintenance.



Manufacturer's Data and Design Characteristics

Characteristics		HELI				
1.01	Manufacture's Name	HELI				
1.02	Model Designation	CPD15	CPD16	CPD18	CPD18	CPD20
1.03	Configuration Number	SQ-GB1/GB2(P)	SQ-GB1/GB2(P)	SQ-GB1/GB2(P)	SQ-GD1/GD2(P)	SQ-GD1/GD2(P)
1.04	Load Capacity	Q (kg)	1500	1600	1750	2000
1.05	Load Center	c (mm)	500	500	500	500
1.06	Power Type	Battery	Battery	Battery	Battery	Battery
1.07	Operator Type	Seated	Seated	Seated	Seated	Seated
1.08	Wheelbase	L1 (mm)	1292	1400	1400	1508
Wheels & Tyres						
2.01	Tyre Type		SE	SE	SE	SE
2.02	Tyres Number (Front/Rear)		2/2	2/2	2/2	2/2
2.03	Tread(centre of tyre),front	W3 (mm)	910	910	920	920
2.04	Tread(centre of tyre),rear	W2 (mm)	163	163	180	180
2.05	Tyre Size, Front		18 × 7-8	18 × 7-8	200/50-10	200/50-10
2.06	Tyre Size, Rear		15 × 4.5-8	15 × 4.5-8	140/55-9	140/55-9
Dimensions						
3.01	Load Distance	L2 (mm)	365	365	365	365
3.02	Mast Tilt Angle,F/R	a/β (°)	5/7	5/7	5/7	5/7
3.03	Height with Mast Lowered	H1 (mm)	2175	2175	2175	2175
3.04	Free Lift	H3 (mm)	90	90	90	90
3.05	Standard Lift Height	H (mm)	3300	3300	3300	3300
3.06	Height with Mast Extended	H2 (mm)	4345	4345	4345	4345
3.07	Overhead Guard Height	H4 (mm)	2040	2040	2040	2040
3.08	Fork Size T × W × L	L4/W/T(mm)	35 × 100 × 920	35 × 100 × 920	35 × 100 × 920	40 × 122 × 920
3.09	Fork Carriage to DIN 15173 A/B		2A	2A	2A	2A
3.10	Length to fork face	l' (mm)	1842	1950	1950	2068
3.11	Overall Width	W1 (mm)	1060	1060	1120	1120
3.12	Outside Turning Radius	r (mm)	1477	1585	1585	1703
3.13	Ground Clearance at mast ,Loaded	H5 (mm)	85	85	90	90
3.14	Ground Clearance at centre of wheelbase ,Loaded	H6 (mm)	100	100	100	100
3.15	Right Stack Aisle width (Pallet size 1000x1000mm, clearance:200mm)	Ast (mm)	3130	3238	3238	3346
3.16	Right Stack Aisle width (Pallet size 1200x1200mm, clearance:200mm)	Ast (mm)	3353	3461	3461	3579
3.17	Lateral Fork Adjustment (Outside of Forks) Max./Min.	W5 (mm)	960/200	960/200	1030/200	1030/245
Performances						
4.01	Travel Speed,loaded/unloaded	km/h	16/16	16/16	16/16	16/16
4.02	Lifting Speed,loaded/unloaded	m/s	0.38/0.6	0.43/0.6	0.43/0.6	0.40/0.60
4.03	Lowering Speed,loaded/unloaded	m/s	0.50/0.40	0.50/0.40	0.50/0.40	0.50/0.40
4.04	Gradient performance with loaded	%	20	20	20	20
4.05	Max. draw bar pull with load	N	15300	15300	15300	17000
Weight						
5.01	Total Approximate Weight(W/O battery)	kg	3000/2280	3200/2300	3300/2400	3350/2300
5.02	Axle Loading*: Unloaded,Front/Rear	kg	1480/1520	1550/1650	1600/1700	1630/1720
5.03	Axle Loading*: Loaded,Front/Rear	kg	3990/510	4250/550	4400/650	4400/700
Battery						
6.01	Battery Voltage/rated capacity(5h)	V/Ah	48/440	48/600	48/600	48/720
6.02	battery weight	kg	680(660-850)	895(800-1000)	895(800-1000)	1064(900-1200)
6.03	Battery to DIN 43531/35/36/A/B/C		43531A	43531A	43531A	43531A
Motor & Controller						
7.01	Drive Motor – 60 Min. Rating	kW	6x2	6x2	6x2	6x2
7.02	Pump Motor – S3 15% Rating	kW	11	11	17.6	17.6
7.03	Drive Motor Control Method		MOSFET/AC	MOSFET/AC	MOSFET/AC	MOSFET/AC
7.04	Pump Motor Control Method		MOSFET/AC	MOSFET/AC	MOSFET/AC	MOSFET/AC
7.05	Service Brake/Parking Brake		Electric/Electric	Electric/Electric	Electric/Electric	Electric/Electric
7.06	Relief Pressure	Mpa	17.5	21	17.5	17.5

NOTE: (1)Detailed information about battery,please contact our salesman or engineer.(2) "P" Battery side extraction(side pulling or side loading),side pulling for standard.
(3)For configuration number, 1: CURTIS Controller; 2: ZAPI Controller.

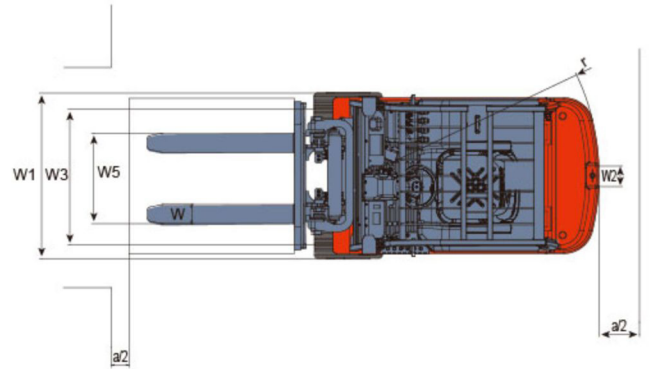
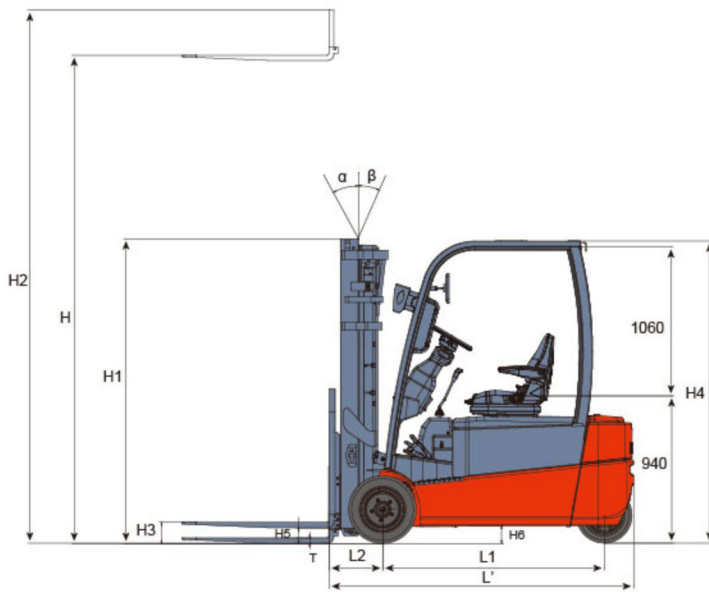

Ast: Right angle stacking aisle width
a: Clearance, 200mm

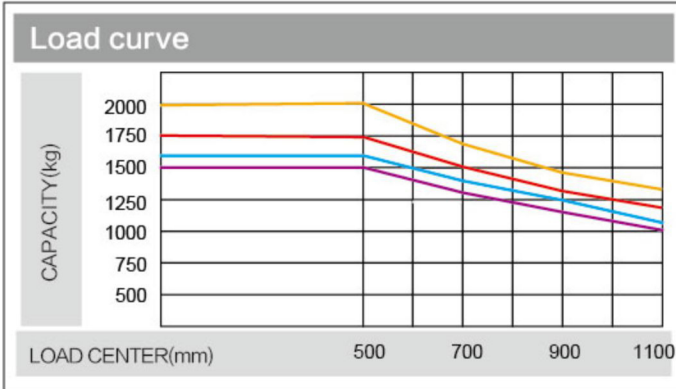

CPD15 CPD16 CPD18 CPD20

Note: The vertical axis stands for load capacity and the horizontal axis stands for load center which is calculated from the front surface of the forks to the gravity of the standard load. The standard load means a cubic with 1000mm edge length. When mast is tilted forward, using non-standard forks or loading large goods, the load capacity will be reduced. The load capacity of standard mast at different load center can be known from this load chart.

BATTERY COMPARTMENT SIZE

MODEL	COMPARTMENT SIZE	BATTERY SPECIFICATIONS	
	WD × LG × HT	SIZE	STANDARD
CPD15SQ-GB	845X532X660	830X522X627	DIN 43531A
CPD16SQ-GB CPD18SQ-GB	845X640X660	830X630X627	DIN 43531A
CPD18SQ-GD CPD20SQ-GD	845X748X660	830X738X627	DIN 43531A



RENEWABLE ENERGY TECHNOLOGIES

With the use of the excellent load-sensing steering system and AC controlling renewable energy technologies, the forklift is more energy-saving and the working hour of the battery is extended by 15%.



15%

WIDE VIEW MAST

Mast model	Max. Lift height (mm)	Capacity at 500mm;load center						Tilting Angle (α/β)	service weight(Kg)				
		1.5t	1.6t	1.8t	1.8t-long wheelbase	2.0t	1.5-2t		1.5t	1.6t	1.8t	1.8t-long wheelbase	2.0t
M200	2000	1500	1600	1750	1750	2000	1525	5-7	2931	3131	3231	3281	3381
M250	2500	1500	1600	1750	1750	2000	1775	5-7	2957	3157	3257	3307	3407
M300	3000	1500	1600	1750	1750	2000	2025	5-7	2984	3184	3284	3334	3434
M330	3300	1500	1600	1750	1750	2000	2175	5-7	3000	3200	3300	3350	3450
M350	3500	1500	1600	1750	1750	2000	2275	5-7	3010	3210	3310	3360	3460
M370	3700	1500	1600	1750	1750	2000	2375	5-7	3024	3224	3324	3374	3474
M400	4000	1500	1600	1750	1750	1950	2575	3-5	3068	3268	3368	3418	3518
M425	4250	1500	1600	1750	1750	1900	2700	3-5	3081	3281	3381	3431	3531
M450	4500	1400	1500	1700	1700	1850	2825	3-5	3094	3294	3394	3444	3544
M500	5000	1300	1400	1600	1600	1700	3075	3-3	3120	3320	3420	3470	3570
M550	5500	1100	1200	1400	1400	1400	3375	3-3	3201	3401	3501	3551	3651
M600	6000	800	900	1000	1000	1100	3625	3-3	3230	3430	3530	3580	3680

WIDE VIEW FULL FREE 2-STAGE MAST

Mast model	Max. Lift height (mm)	Capacity at 500mm;load center						Height with mast lowered (mm)	Free lift (with Backrest)	Tilting Angle (α/β)	service weight(Kg)				
		1.5t	1.6t	1.8t	1.8t-long wheelbase	2.0t	1.5-2t				1.5-2t	1.5t	1.6t	1.8t	1.8t-long wheelbase
ZM200	2000	1500	1600	1750	1750	2000	1525	510	5-7	2962	3162	3262	3312	3412	
ZM250	2500	1500	1600	1750	1750	2000	1775	760	5-7	2990	3190	3290	3340	3440	
ZM300	3000	1500	1600	1750	1750	2000	2025	1010	5-7	3019	3219	3319	3369	3469	
ZM330	3300	1500	1600	1750	1750	2000	2175	1160	5-7	3036	3236	3336	3386	3486	
ZM350	3500	1500	1600	1750	1750	2000	2275	1260	5-7	3047	3247	3347	3397	3497	
ZM370	3700	1500	1600	1750	1750	2000	2375	1360	5-7	3062	3262	3362	3412	3512	
ZM400	4000	1500	1600	1750	1750	1950	2575	1560	3-5	3106	3306	3406	3456	3556	

NOTE: 1.5-2T:free lifted height 394mm increased without backrest.

WIDE VIEW FULL FREE 3-STAGE MAST

Mast model	Max. Lift height (mm)	Capacity at 500mm;load center						Height with mast lowered (mm)	Free lift (with Backrest)	Tilting Angle (α/β)	service weight(Kg)				
		1.5t	1.6t	1.8t	1.8t-long wheelbase	2.0t	1.5-2t				1.5-2t	1.5t	1.6t	1.8t	1.8t-long wheelbase
ZSM360	3600	1500	1600	1750	1750	2000	1790	775	3-5	3133	3333	3433	3483	3583	
ZSM400	4000	1500	1600	1750	1750	2000	1925	910	3-5	3160	3360	3460	3510	3610	
ZSM435	4350	1400	1500	1700	1700	1900	2040	1025	3-5	3184	3384	3484	3534	3634	
ZSM450	4500	1400	1500	1700	1700	1850	2090	1075	3-5	3194	3394	3494	3544	3644	
ZSM470	4700	1350	1450	1650	1650	1750	2160	1145	3-5	3208	3408	3508	3558	3658	
ZSM480	4800	1350	1450	1650	1650	1750	2190	1175	3-5	3214	3414	3514	3564	3664	
ZSM500	5000	1200	1300	1600	1600	1700	2290	1275	3-3	3234	3434	3534	3584	3684	
ZSM540	5400	1050	1150	1250	1250	1400	2425	1410	3-3	3262	3462	3562	3612	3712	
ZSM600	6000	800	900	1000	1000	1100	2640	1625	3-3	3305	3505	3605	3655	3755	
ZSM650	6500	700	800	900	900	1000	2830	1815	3-3	3343	3543	3643	3693	3793	

NOTE: 1.5-2T:free lifted height 364mm increased without backrest.

1.5-2T:free lifted height 364mm increased without backrest when assemble with pulley block.

Reliable special designed instrument

Alphanumeric display Battery discharge indicator

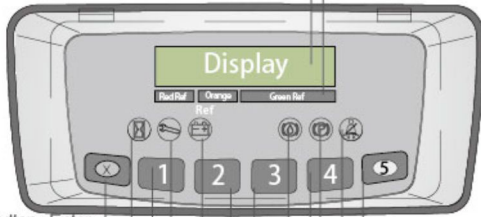

- Keyboard button : Enter
- Waiting LED (NO USE)
- Keyboard button :Roll up
- Failure alarm LED
- Low battery LED
- Keyboard button :Roll down
- Keyboard button :Out
- Seat switch LED
- Hand brake status LED
- Keyboard button :Set down
- Oil position LED (NO USE)
- Keyboard button :Set up

ZAPI Display

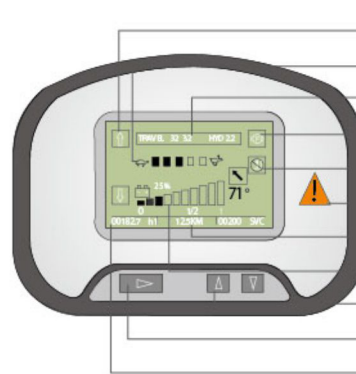

- Driving direction
- Driving speed state
- Fault code
- Hand brake status
- Lift lockout
- Caution light
- Speed indicator
- Battery capacity
- Driving mode selection button
- Program menu button
- Hour meter

CURTIS Display

standard configuration

- Wide view standard mast
- Standard fork
- Class II standard carriage
- Load backrest
- Two-spool control valve
- Battery
- Standard seat
- Overhead guard
- Overhead guard rain cover

- LCD combined display
- Solid tires
- Traction pin
- LED signal light, LED warning light(flashing)
- Back-up alarm
- Automatic steering slow down device
- Automatic Packing
- Drive's tool

Optional device

- Cab
- Side shifter
- Rotator
- Load stabilizer
- LED Warning lights(rotating/buzzer)
- Coloring tires(white/green)
- Rear work light
- Steel fence
- Long forks

- Accessory hydraulic component
- Tilt cylinder protection sleeve
- Customer color
- Battery lifting sling
- Battery side-pull
- Finger tips