



HELI

6t / 8t / 10t

H2000 series Internal Combustion Counterbalanced Forklift Truck

Enter Into Container Forklift Truck



Manufacturer's Data and Design Characteristics

1	Model			CPCD60	CPCD80	CPCD100
2	Rated capacity		kg	6000	8000	10000
3	Load center		mm	600	600	600
4	Max.lifting height	H	mm	2400	2000	2000
5	Free lifting height(without backrest)		mm	200	200	200
6	Mast tilting angle	α/β	°	6/12	6/12	6/12
7	Max.lifting speed (with/without load)		mm/s	490/520	485/520	330/370
8	Max.travelling speed (with/without load)		km/h	24/26	24/26	25/29
9	Max.gradeability(loaded)		%	33	25	22
10	Max.drawbar pull(loaded)		kN	60	70	62
11	Wheel base	L1	mm	2250	2250	2800
12	Tread(front/rear)	W3/W2	mm	1442/1500	1442/1500	1422/1500
13	Overhang (front/rear)	L2/L3	mm	595/715	625/855	670/840
14	Over length (with 1220mm fork)	L	mm	4780	4960	5530
15	Over width (front/rear)	W1/W4	mm	1945/1750	1945/1750	1945/1770
16	Overall height (overhead guard)	H4	mm	2230	2230	2230
17	Overhead guard clearance (from face of seat)	H6	mm	1000	1000	1000
18	Min.turning radius		mm	3280	3400	4000
19	Min.ground clearance under axle		mm	130	130	267
20	Service weight			8990	9980	10900
21	Front tyre type			4-250-15 Solid	4-250-15 Solid	4-8.25-20-14PR
22	Rear tyre type			2-250-15-16PR	2-250-15-16PR	2-9.00-16-14PR
23	IC engine model			Perkins 1104D-44TA		
24	Rated power/speed		kW/rpm	83/2200		
25	Max.torque/speed		N.m/rpm	418/1400		

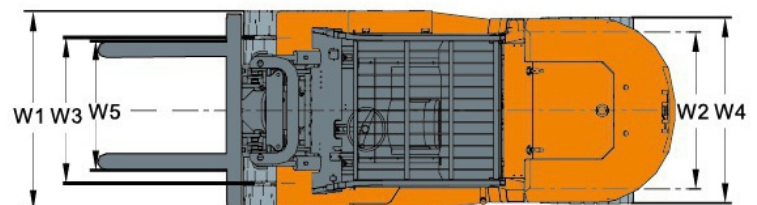
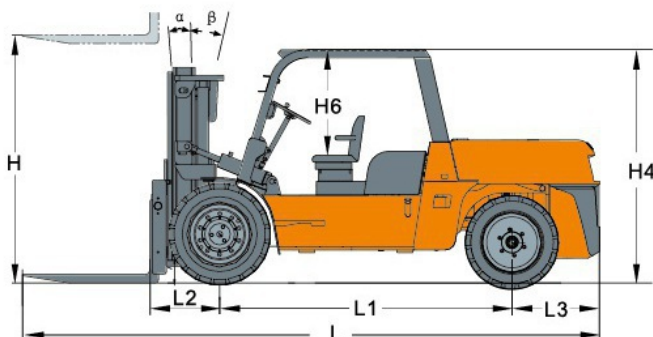



HELI newly developed 6ton/8ton/10ton the container inner operation forklift truck is designed specially for people to handle cargos in containers.

The product also can be used in height limit space (e.g. cabin of vessel) to load/unload cargos too.

6T/8T/10T Advantages

- Low height of truck is suitable for container working; narrow truck body enhance truck maneuverability.
- The truck is comfortable for operation and seat space satisfy the requirements of GB/T5143-2018.
- Low dashboard height improves operator's view effectively.
- New design of radiator with superior cooling performance satisfies the requirements of working in container, cabin and places with poor ventilation.
- Full hydraulic power brake needs small operation force and it is safe and reliable.
- Electro-hydraulic directional control is convenient for operation.
- Steering axle with buffer device ensures good damping effect.
- 2-stage mast is standard and full-free 2-stage mast and side shifter are optional.

CPCD60 CPCD80 CPCD100

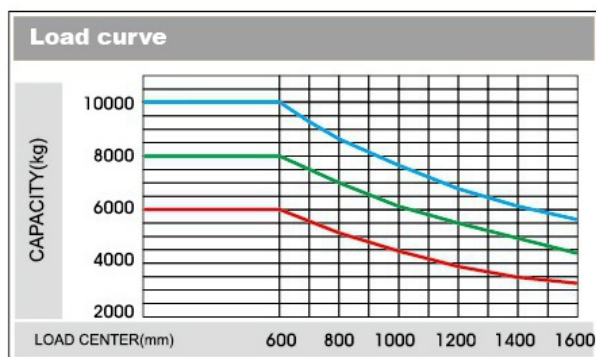

Notice:

Vertical axle stands for load capacity while horizontal axle stands for load center. Load center is the distance counted from the front of the fork. The base point of the standard load is the center point of the cubic with the same 1000mm dimension in length, width and height. The load capacity should be down, if mast tilts forward, using non-standard forks or loading goods with extra width. Please notice the different load capacity between different load centers according to load chart.



Enter Into
Container Forklift Truck

6t/8t/10t

Internal combustion
counterbalanced
forklift truck

FULL FREE 2-STAGE MAST FOR OPTION

Forklift tonnage	Mast model	Load capacity(kg)	Mast height (lowered)(mm)	Free lift(without/with backrest)(mm)	Tilting angle(°)
6t	ZM200	6000	1950	980/780	6° /12°
	ZM250		2200	1230/1030	
8t	ZM200	8000	1950	980/780	
	ZM250		2200	1230/1030	
10t	ZM210	10000	2190	1100(Without backrest)	

ENGINE MODEL AND MAIN SPECIFICATION FOR OPTION

Forklift tonnage	IC engine model	Rated power/Speed (kW/rpm)	Max. torque/Speed (Nm/rpm)	Engine cylinder number
6t	ISUZU A-6BG1	82/2000	415/1400-1600	6
8t	XiChai6110	83/2000	450/1400-1500	6
10t	XiChai6110	83/2000	450/1400-1500	6
10t	ISUZU A-6BG1	82/2000	415/1400-1600	6
10t	CUMMINS QSF3.8	86/2200	470/1100-1700	4

