

1-2.5 t

**H3 series
AC Electric Forklift Truck**



Improved driver's view

- > Standard configuration of wide view mast, compact structure of mast and tube pulley block.
- > Large arc of overhead guard and angle optimized grid tray enlarge driver's upper view.

Improved operating comfort

- > 25mm lowered pedal height, 100% enlarged accelerator panel and 40% enlarged brake pedal improve driver's foot operating comfort.
- > Super low torque steering unit makes steering light and easy.
- > Rear handle with horn button ensures safe and comfortable operation while reverse driving.
- > Mast and rear axle buffering improve driving comfort largely.
- > Ratchet hand brake has different brake force on slope and ground, reducing driver's fatigue.

Optimized maintainability and safety

- > Special side plate and top cover structure is easy for assembly and disassembly.
- > Highly-mounted rear axle increasing transversal stability by 2.1%.
- > Two driving modes offer optional choices to different working condition.
- > Automatic deceleration when steering is optional so as to ensure the operation safety.

High efficiency and energy-saving

- > The use of electric truck dedicated tire with pattern saves more than 10% of the energy during travelling.
- > LED lamps save 80% of the energy.
- > The professional matching design of the components prolongs the battery working time about 10%.

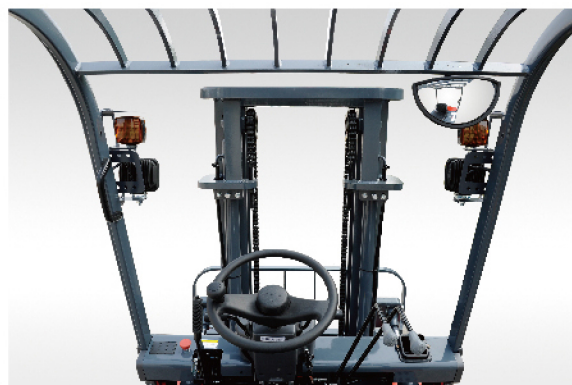

Manufacturer's Data and Design Characteristics

Character				HELI											
1.01	Manufacturer														
1.02	Model			CPD10	CPD15	CPD15	CPD18	CPD20	CPD25	CPD10	CPD15	CPD15	CPD18	CPD20	CPD25
1.03	Configuration number			HA1/HA2/HA3	HA1/HA2/HA3	HC1/HC2/HC3	HC1/HC2/HC3	HA1/HA2/HA3	HA1/HA2/HA3	HB2/HB3	HB2/HB3	HD2/HD3	HD2/HD3	HB2/HB3	HB2/HB3
1.04	Rated capacity	Q	kg	1000	1500	1500	1750	2000	2500	1000	1500	1500	1750	2000	2500
1.05	Load center	c	mm	500	500	500	500	500	500	500	500	500	500	500	500
1.06	Power mode			Battery	Battery	Battery	Battery	Battery	Battery	Battery	Battery	Battery	Battery	Battery	Battery
1.07	Driving mode			Seated	Seated	Seated	Seated	Seated	Seated	Seated	Seated	Seated	Seated	Seated	Seated
1.08	Wheel base	L1	mm	1280	1280	1390	1390	1535	1535	1280	1280	1390	1390	1535	1535
Tyre															
2.01	Tyre type			Pneumatic	Pneumatic	Pneumatic	Pneumatic	Pneumatic	Pneumatic	Pneumatic	Pneumatic	Pneumatic	Pneumatic	Pneumatic	Pneumatic
2.02	Wheel number(front/rear)			2/2	2/2	2/2	2/2	2/2	2/2	2/2	2/2	2/2	2/2	2/2	2/2
2.03	Front wheel base	W3	mm	890	890	890	920	960	960	890	890	890	920	960	960
2.04	Rear wheel base	W2	mm	920	920	920	920	950	950	920	920	920	920	950	950
2.05	Tyre (front)			6.50-10-10PR	6.50-10-10PR	6.50-10-10PR	6.50-10-10PR	7.00-12-12PR	7.00-12-12PR	6.50-10-10PR	6.50-10-10PR	6.50-10-10PR	6.50-10-10PR	7.00-12-12PR	7.00-12-12PR
2.06	Tyre(rear)			16 x 6-8-10PR	16 x 6-8-10PR	16 x 6-8-10PR	16 x 6-8-10PR	18 x 7-8-14PR	18 x 7-8-14PR	16 x 6-8-10PR	16 x 6-8-10PR	16 x 6-8-10PR	16 x 6-8-10PR	18 x 7-8-14PR	18 x 7-8-14PR
Size															
3.01	Front overhang	L2	mm	410	410	410	410	465	465	410	410	410	410	465	465
3.02	Mast tilt angle , front/rear	α/β	°	6/12	6/12	6/12	6/12	6/12	6/12	6/12	6/12	6/12	6/12	6/12	6/12
3.03	Height with mast retraction	H1	mm	1995	1995	1995	1995	2000	2000	1995	1995	1995	1995	2000	2000
3.04	Free lifting height	H3	mm	150	150	150	150	170	170	150	150	150	150	170	170
3.05	Max. Lifting height	H	mm	3000	3000	3000	3000	3000	3000	3000	3000	3000	3000	3000	3000
3.06	Max. Height under working condition	H2	mm	4040	4040	4040	4040	4042	4042	4040	4040	4040	4040	4042	4042
3.07	Overhead guard height	H4	mm	2130	2130	2130	2130	2155	2155	2130	2130	2130	2130	2155	2155
3.08	Fork size:thickness*width*length	T×W×L4	mm	32 × 100 × 770	35 × 100 × 920	35 × 100 × 920	35 × 100 × 920	40 × 122 × 920	40 × 122 × 1070	32 × 100 × 770	35 × 100 × 920	35 × 100 × 920	35 × 100 × 920	40 × 122 × 920	40 × 122 × 1070
3.09	Fork arm carrier, ISO 2328,class/ type A,B			2A	2A	2A	2A	2A	2A	2A	2A	2A	2A	2A	2A
3.10	Truck body length (fork excluded)	L'	mm	2065	2065	2175	2175	2400	2400	2065	2065	2175	2175	2400	2400
3.11	Truck body width	W1	mm	1086	1086	1086	1086	1170	1170	1086	1086	1086	1086	1170	1170
3.12	Turning radius	r	mm	1770	1770	1880	1880	2065	2065	1770	1770	1770	1880	1880	2065
3.13	Clearance between mast and ground	H5	mm	110	110	110	110	115	115	110	110	110	110	115	115
3.14	Clearance between wheel base center and ground(loaded)	H6	mm	120	120	120	120	135	135	120	120	120	120	135	135
3.15	Right angle stacking aisle width (Pallet1000x1000mm , clearance 200mm)	Ast	mm	3380	3380	3490	3490	3730	3800	3380	3380	3490	3490	3730	3800
3.16	Right angle stacking aisle width (Pallet1200x1200mm , clearance 200mm)	Ast	mm	3580	3580	3690	3690	3930	3930	3580	3580	3690	3690	3930	3930
3.17	lateral fork adjustment (Outside of forks) max./min.			960/200	960/200	960/200	960/200	1030/244	1030/244	960/200	960/200	960/200	960/200	1030/244	1030/244
Performance															
4.01	Travelling speed: loaded/unloaded		km/h	14/15	14/15	14/15	14/15	14/15	14/15	14/15	14/15	14/15	14/15	14/15	14/15
4.02	Lifting speed: loaded/unloaded		m/s	0.29/0.45	0.27/0.45	0.27/0.45	0.28/0.53	0.28/0.49	0.26/0.49	0.35/0.49	0.34/0.49	0.34/0.49	0.33/0.49	0.35/0.44	0.31/0.44
4.03	Lowering speed		m/s	0.45	0.45	0.45	0.45	0.45	0.45	0.45	0.45	0.45	0.45	0.45	0.45
4.04	Gradeability (loaded)		%	18	17	17	15	16	15	18	17	17	15	16	15
4.05	Max. Traction force (loaded)		N	7800	8600	8800	9500	12300	12800	7800	8600	8800	9500	12300	12800
4.06	Acceleration time (10m) loaded/unloaded		s	5.2/5.0	5.4/5.2	5.4/5.2	5.6/5.4	5.6/5.4	6.2/6.0	5.2/5.0	5.4/5.2	5.4/5.2	5.6/5.4	5.6/5.4	6.2/6.0
Weight															
5.01	Total weight (with /without battery)		kg	2680/2030	2950/2300	2980/2220	3150/2390	4080/3080	4230/3230	2680/2030	2950/2300	2980/2220	3150/2390	4080/3080	4230/3230
5.02	Axle load; unloaded, front/rear		kg	1215/1465	1330/1620	1445/1535	1450/1700	1960/2120	1950/2280	1215/1465	1330/1620	1445/1535	1450/1700	1960/2120	1950/2280
5.03	Axle load; loaded, front/rear		kg	3080/600	3900/550	3930/550	4400/500	5220/860	6020/710	3080/600	3900/550	3930/550	4400/500	5220/860	6020/710
Battery															
6.01	Battery voltage/capacity ks		V/Ah	48/400	48/400	48/480	48/480	48/600	48/600	48/400	48/400	48/480	48/480	48/600	48/600
6.02	Battery weight		kg	650(650-900)	650(650-900)	750(750-1050)	750(750-1050)	980(980-1300)	980(980-1300)	650(650-900)	650(650-900)	750(750-1050)	750(750-1050)	980(980-1300)	980(980-1300)
6.03	Battery, din standard			43531A	43531A	43531A	43531A	43531B	43531B	43531A	43531A	43531A	43531A	43531B	43531B
Motor and controller															
7.01	Drive motor power-60 minutes		kW	8.0	8.0	8.0	8.0	11	11	8.0	8.0	8.0	8.0	11	11
7.02	Lifting motor power(s3 15%)		kW	7.5	7.5	7.5	8.6	10.5	10.5	10.0	10.0	10.0	10.0	12.0	12.0
7.03	Drive motor controlling mode			MOSFET/AC	MOSFET/AC	MOSFET/AC	MOSFET/AC	MOSFET/AC	MOSFET/AC	MOSFET/AC	MOSFET/AC	MOSFET/AC	MOSFET/AC	MOSFET/AC	MOSFET/AC
7.04	Lifting motor controlling mode			MOSFET/DC	MOSFET/DC	MOSFET/DC	MOSFET/DC	MOSFET/DC	MOSFET/DC	MOSFET/AC	MOSFET/AC	MOSFET/AC	MOSFET/AC	MOSFET/AC	MOSFET/AC
7.05	Service brake/parking brake			Hydraulic/Mechanical	Hydraulic/Mechanical	Hydraulic/Mechanical	Hydraulic/Mechanical	Hydraulic/Mechanical	Hydraulic/Mechanical	Hydraulic/Mechanical	Hydraulic/Mechanical	Hydraulic/Mechanical	Hydraulic/Mechanical	Hydraulic/Mechanical	Hydraulic/Mechanical
7.06	Hydraulic system working pressure		Mpa	14.5	14.5	14.5	17.5	17.5	17.5	14.5	14.5	14.5	14.5	17.5	17.5

NOTE: 1.*Detailed information about battery, please contact our salesmen or engineer.
2. For configuration number, 1; CURTIS Controller; 2; ZAPI Controller; 3; Inmotion Controller.

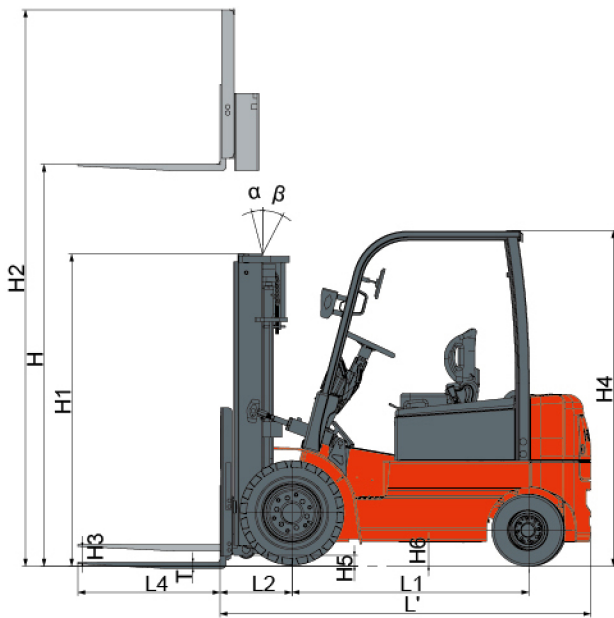

Ast: Right angle stacking aisle width

a: Clearance

b: Load Length

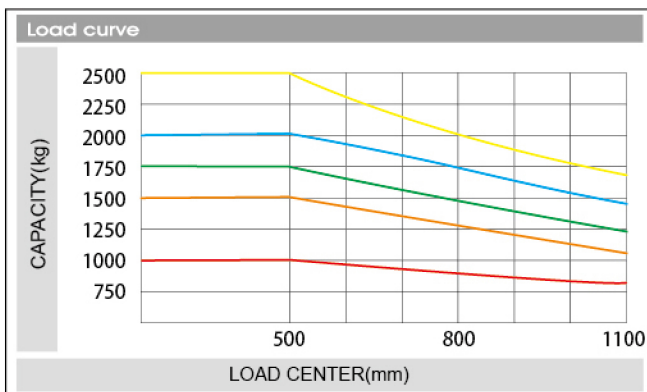
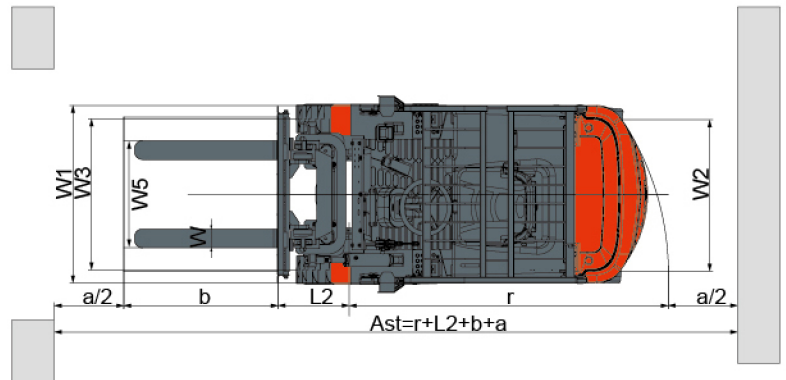

CPD10 CPD15 CPD18 CPD20 CPD25

Note: The vertical axis stands for load capacity and the horizontal axis stands for load center which is calculated from the front surface of the forks to the gravity of the standard load. the standard load means a cubic with 1000mm edge length. When mast is tilted forward, using non-standard forks or loading large goods, the load capacity will be reduced. The load capacity of standard mast at different load center can be known from this load chart.

WIDE VIEW MAST															
mast model	Max. lifting height mm	load capacity (load center 500mm) (kg)					mast overall height (fork to the ground) (mm)		service weight (kg)					mast tilt angle (°) α/β	
		1t	1.5t	1.8t	2t	2.5t	1-1.8t	2-2.5t	1t	1.5t(A)	1.5t(C)	1.8t	2t		2.5t
M200	2000	1000	1500	1750	2000	2500	1495	1500	2615	2885	2915	3085	3990	4140	6/12
M250	2500	1000	1500	1750	2000	2500	1745	1750	2645	2915	2945	3115	4035	4185	6/12
M300	3000	1000	1500	1750	2000	2500	1995	2000	2680	2950	2980	3150	4080	4230	6/12
M330	3300	1000	1500	1750	2000	2500	2145	2150	2700	2970	3000	3170	4105	4255	6/12
M350	3500	1000	1500	1750	2000	2500	2245	2250	2710	2980	3010	3180	4125	4275	6/12
M370	3700	1000	1500	1750	2000	2500	2345	2350	2725	2995	3025	3195	4140	4290	6/6
M400	4000	1000	1500	1700	2000	2450	2545	2550	2775	3045	3075	3245	4200	4350	6/6
M425	4250	1000	1400	1650 *1750	1850	2250	2670	2675	2790	3060	3090	3260	4225	4375	6/6 *6/12
M450	4500	950	1350	1550 *1700	1800	2150	2795	2800	2805	3075	3105	3275	4250	4400	6/6 *6/12
M500	5000	930	1000 *1250	1000 *1600	1600 *1700	1600 *2000	3045	3050	2840	3110	3140	3310	4295	4445	6/6 *6/6
M550	5500	900	900 *1150	950 *1500	1500 *1600	1500 *1900	3345	3350	2900	3170	3200	3370	4370	4520	3/6 *3/6
M600	6000	600 *850	600 *1050	600 *1400	950 *1500	950 *1800	3595	3600	2930	3200	3230	3400	4420	4570	3/6 *3/6

NOTE: (1) * refers to rated capacity with double tires.

WIDE VIEW FULL FREE 2-STAGE MAST

mast model	Max. lifting height mm	load capacity (load center 500mm) (kg)					mast overall height (fork to the ground) (mm)		free lifting height (with backrest) (mm)		service weight (kg)						mast tilt angle (°) α/β
		1t	1.5t	1.8t	2t	2.5t	1-1.8t	2-2.5t	1-1.8t	2-2.5t	1t	1.5t(A)	1.5t(C)	1.8t	2t	2.5t	
ZM200	2000	1000	1500	1750	2000	2500	1495	1500	485	495	2660	2930	2960	3130	4000	4150	6/12
ZM250	2500	1000	1500	1750	2000	2500	1745	1750	735	745	2690	2960	2990	3160	4045	4195	6/12
ZM300	3000	1000	1500	1750	2000	2500	1995	2000	985	840	2725	2995	3025	3195	4095	4245	6/12
ZM330	3300	1000	1500	1750	2000	2500	2145	2150	1135	990	2750	3020	3050	3220	4115	4265	6/12
ZM350	3500	1000	1500	1750	2000	2500	2245	2250	1235	1090	2760	3030	3060	3230	4145	4295	6/12
ZM370	3700	1000	1500	1750	2000	2450	2345	2350	1335	1205	2775	3045	3075	3245	4160	4310	6/6
ZM400	4000	1000	1500	1750	2000	2400	2545	2550	1535	1390	2825	3095	3125	3295	4225	4375	6/6
ZM425	4250	1000	1400	1650 *1750	1850	2250	2670	2675	1660	1515	2840	3110	3140	3310	4250	4400	6/6 *6/12
ZM450	4500	950	1350	1550 *1700	1800	2150	2795	2800	1785	1640	2860	3130	3160	3330	4275	4425	6/6 *6/12
ZM500	5000	930	1000 *1250	1000 *1600	1600 *1700	1600 *2000	3045	3050	2035	1910	2895	3165	3195	3365	4320	4470	6/6 *6/6
ZM550	5500	900	950 *1150	950 *1500	1500 *1600	1500 *1900	3345	3350	2335	2190	2955	3225	3255	3425	4405	4555	3/6 *3/6
ZM600	6000	600 *850	600 *1050	600 *1400	950 *1500	950 *1800	3595	3600	2585	2440	2990	3260	3290	3460	4455	4605	3/6 *3/6

NOTE: (1) * refers to rated capacity with double tires.
 (2) 1-1.8T: free lifted height 365mm increased without backrest.
 (3) 2-2.5T: free lifted height 290mm increased without backrest.

WIDE VIEW FULL FREE 3-STAGE MAST

mast model	Max. lifting height mm	load capacity (load center 500mm) (kg)					mast overall height (fork to the ground) (mm)		free lifting height (with backrest) (mm)		service weight (kg)						mast tilt angle (°) α/β
		1t	1.5t	1.8t	2t	2.5t	1-1.8t	2-2.5t	1-1.8t	2-2.5t	1t	1.5t(A)	1.5t(C)	1.8t	2t	2.5t	
ZSM360	3600	1000	1450	1750	2000	2400	1790	1795	695	795	2775	3045	3075	3245	4205	4355	6/6
ZSM400	4000	1000	1400	1600	1900	2300	1925	1920	910	920	2800	3070	3100	3270	4240	4390	6/6
ZSM435	4350	950	1300	1500 *1700	1850	2200	2040	2045	1025	1045	2820	3090	3120	3290	4275	4425	6/6 *6/6
ZSM450	4500	950	1300	1500 *1650	1750	2100	2090	2095	1075	1095	2830	3100	3130	3300	4285	4435	6/6 *6/6
ZSM470	4700	930	1280	1450 *1600	1720	2000	2160	2160	1075	1160	2850	3120	3150	3320	4305	4455	6/6 *6/6
ZSM480	4800	920	1250	1400 *1580	1700	1950	2190	2195	1145	1195	2860	3130	3160	3330	4315	4465	6/6 *6/6
ZSM500	5000	900	1000 *1200	1000 *1550	1600	1600 *1900	2290	2295	1275	1295	2880	3150	3180	3350	4345	4495	6/6 *6/6
ZSM540	5400	750 *900	800 *1150	800 *1480	1500	1500 *1800	2415	2420	1400	1420	2900	3170	3200	3370	4385	4535	3/6 *3/6
ZSM600	6000	550 *850	550 *1050	550 *1380	950 *1450	950 *1700	2640	2645	1625	1645	2975	3245	3275	3445	4450	4600	3/6 *3/6
ZSM650	6500	*800	*1000	*1250	600 *1300	600 *1500	2840	2835	1815	1835	3010	3280	3310	3480	4505	4655	3/3 *3/3
ZSM700	7000	*650	*750	*900	*1000	*1100	3025	3105	2010	2105	3050	3320	3350	3520	4570	4720	*3/3

NOTE: (1) * refers to rated capacity with double tires.
 (2) 1-1.8T: free lifted height 480mm increased without backrest.
 (3) 1-1.8T: free lifted height 440mm increased without backrest when assembled with pulley block.
 (4) 2-2.5T: free lifted height 320mm increased without backrest.
 (5) 2-2.5T: free lifted height 90mm increased without backrest when assembled with pulley block.

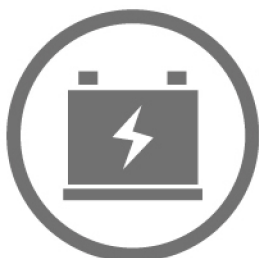

RENEWABLE ENERGY TECHNOLOGIES

With the use of the excellent load-sensing steering system and AC controlling renewable energy technologies, the forklift is more energy-saving and the working hour of the battery is extended by 15%.



15%

Reliable special designed instrument

The reliable special instrument gives a complete display of the vital information, like operation status, fault detection, etc. It ensures the operator predominate the vehicle status more intuitive and convenient.

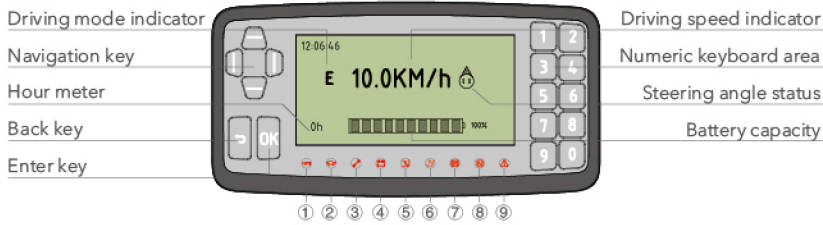

- ① DC type pump controller fault indicator
- ② Turtle indicator
- ③ Fault alarm light
- ④ Low electric quantity indicator
- ⑤ Lifting lock indicator
- ⑥ Seat indicator
- ⑦ Parking brake indicator
- ⑧ Neutral indicator
- ⑨ Warning light

Inmotion Display

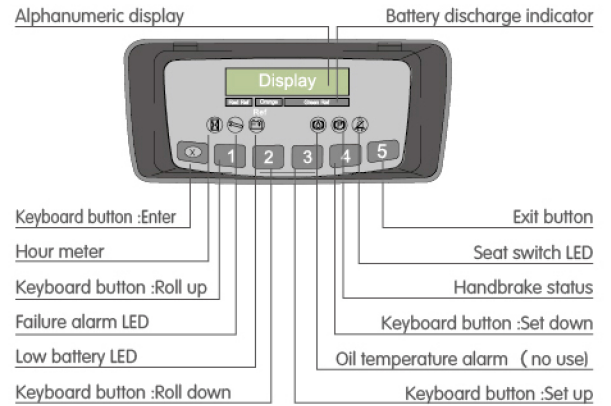

ZAPI Display

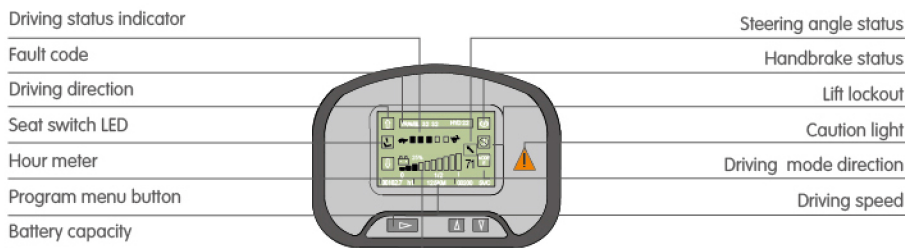

CURTIS Display

standard configuration

- wide view basic mast
- standard fork
- II(III)stage fork arm carrier
- backrest
- control valve
- battery
- standard seat
- overhead guard
- overhead guard rain cover
- liquid crystal combined instrument
- pneumatic tyre
- traction pin
- driver's tool
- LED Lamp
- Horn alert function
- on rear handle

Optional device

- string rod
- driver's cab
- lifting hook
- cargo boom
- tip-over fork
- side shifting
- paper roll clamp
- warning light (Flashing/totating/buzzing)
- solid tyre
- rear working light
- steel protection net
- multipurpose drum clamp
- load stabilizer
- widen fork arm carrier
- lengthening fork
- load pusher
- lengthening fork extension
- rotating flat clamp
- Dual-tyre with protection device
- auxiliary hydraulic valve component
- tilting/steering cylinder jacket
- coloring tyre
- wide view two/three stage full free mast
- customer made color
- Turn automatic deceleration function
- Battery lifting sling
- HELI smart fleet management system