

HPS/HPT Technical Data Hand Pallet Trucks

HPS 20

HPS 20 W

HPS 25

HPS 25 W

HPT 10 XM

HPT 10 XE

HPT 20 FL

HPT 25

HPT 25 GA

HPT 25 ST

HPT 30





				STILL	STILL	STILL	STILL	STILL	STILL	STILL	STILL	STILL	STILL				
Features	1.1	Manufacturer															
	1.2	Manufacturer's type designation			HPS 20	HPS 20 W	HPS 25	HPS 25 W	HPT 10 XM	HPT 10 XE	HPT 20 FL	HPT 25	HPT 25 GA	HPT 25 ST	HPT 30		
	1.4	Operator type			Pedestrian	Pedestrian	Pedestrian	Pedestrian	Pedestrian	Pedestrian	Pedestrian	Pedestrian	Pedestrian	Pedestrian	Pedestrian		
	1.5	Rated capacity/rated load		Q	kg	2000	2000	2500	2500	1000	1000	2000	2500	2500	2500	3000	
	1.6	Load centre distance		c	mm	600	600	600	600	600	600	600	600	600	600	600	
	1.8	Load distance, centre of drive axle to fork		x	mm	972	935	972	935	993	993	945	932	932	932	932	
1.9	Wheel base		y	mm	1218	1120	1218	1120	1231	1231	1192	1192	1192	1192	1192		
Weight	2.1	Service weight			kg	69	104 ²	70	107 ²	104	144 ²	71	63	63	69	79	
Tyres/chassis	3.1	Tyres		drive end/load end		Nylon/nylon ¹	Rubber/polyurethane tandem ¹	Nylon/nylon ¹	Rubber/polyurethane tandem ¹	Nylon/polyurethane ¹	Nylon/polyurethane ¹	Nylon/nylon tandem ¹	Nylon/nylon ¹	Nylon/nylon ¹	Nylon/nylon	Nylon/nylon tandem ¹	
	3.2	Tyre size		drive end	mm	Ø 200 x 50	Ø 180 x 50	Ø 200 x 50	Ø 180 x 50	Ø 200 x 45	Ø 200 x 50	Ø 200 x 50	Ø 200 x 50	Ø 200 x 50	Ø 200 x 50	Ø 200 x 50	Ø 200 x 50
	3.3	Tyre size		load end	mm	Ø 80 x 93	Ø 80 x 70	Ø 80 x 93	Ø 80 x 70	Ø 80 x 50	Ø 80 x 50	Ø 55 x 58	Ø 82 x 82	Ø 82 x 82	Ø 82 x 82	Ø 82 x 60	
	3.5	Number of wheels		drive end/load end		2/2	2/4	2/2	2/4	2/2	2/2	2/4	2/2	2/2	2/2	2/4	
	3.6	Track width		drive end	b ₁₀	mm	130	130	130	130	155	155	125	155	155	155	155
	3.7	Track width		load end	b ₁₁	mm	360	445	360	445	447	447	365	375	375	375	375
Dimensions	4.4	Lift			h ₂	mm	115	115	115	115	715	715	115	115	115	115	
	4.9	Height drawbar in driving position		max.	h ₁₄	mm	1230	1215	1230	1215	1285	1214	1185	1185	1185	1185	1185
	4.15	Fork height, lowered			h ₁₃	mm	85	90	85	90	85	85	56,5	85	85	85	85
	4.19	Overall length			l ₁	mm	1545	1580	1545	1580	1545	1665	1550	1550	1550	1550	1550
	4.20	Length to face of forks			l ₂	mm	395	430	395	430	395	515	400	400	400	400	400
	4.21	Overall width			b ₁	mm	520	555	520	555	540	540	525	525	525	525	525
	4.22	Fork dimensions		DIN ISO 2331	s/e/l	mm	48/160/1150	65/180/1150	48/160/1150	65/180/1150	48/160/1150	48/160/1150	40/160/1150	55/150/1150	55/150/1150	55/150/1150	55/150/1150
	4.25	Distance between fork arms			b ₅	mm	520	555	520	555	540	540	525	525	525	525	525
	4.32	Ground clearance, centre of wheel base			m ₂	mm	37	25	37	25	21	21	15	30	30	30	30
	4.34.1	Working aisle width for pallets 1000 x 1200 crossways			A _{st}	mm	1810	1850	1810	1850	2241	2321	2170	2171	2171	2171	2171
	4.34.2	Working aisle width for pallets 800 x 1200 lengthways			A _{st}	mm	1790	1830	1790	1830	2091	2171	2041	2048	2048	2048	2048
4.35	Turning radius			W _a	mm	1335	1375	1335	1375	1440	1520	1367	1367	1367	1367	1367	

¹ Other wheel/roller treads as per the equipment overview
² Service weight incl. battery

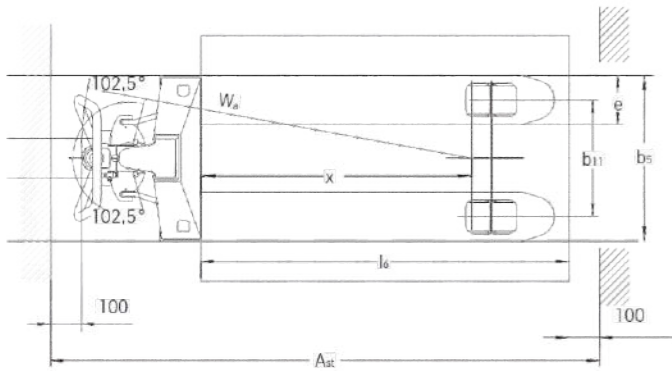

HPS 20 top view

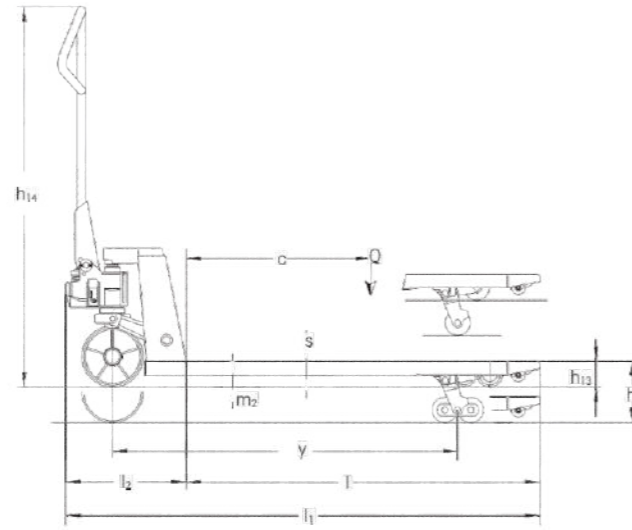

HPS 20 side view

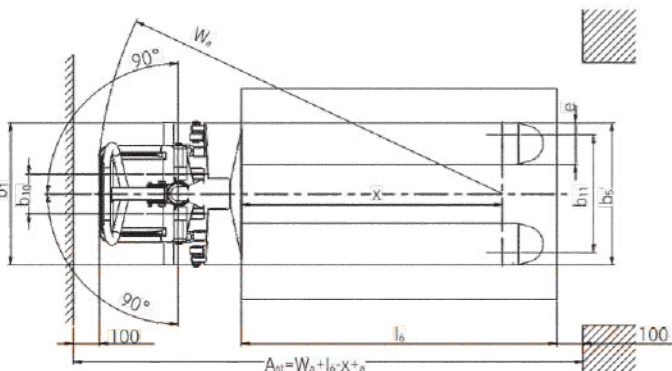

HPT 10 XE top view

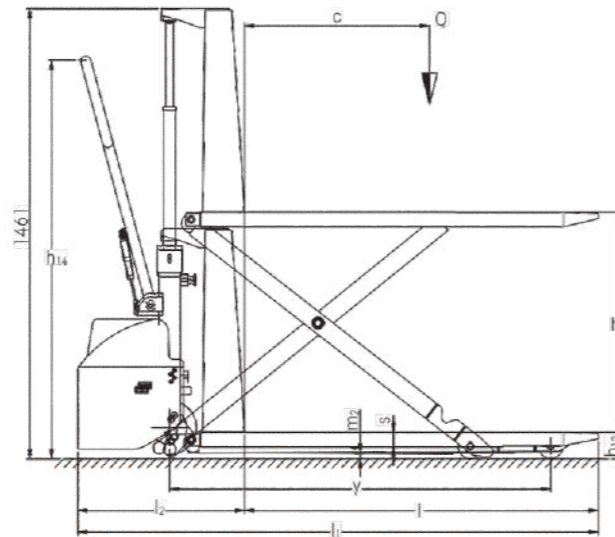

HPT 10 XE side view

HPT Hand Pallet Truck

Impressive all-rounder for loads up to 3000 kg

Maximum steering lock for manoeuvrability in the tightest of spaces

Ergonomic handle design for fatigue-free operation



HPT 25, HPT 30, HPT 20 FL

Hand pallet trucks are versatile, easy to operate and available at all times, making them one of the most popular types of industrial trucks used in logistics. Featuring lifting capacities of up to 2,500 kg and 3,000 kg respectively, the reliable HPT 25/30 models boast an impressively functional design and are incredibly straightforward to use. With its different fork lengths and widths, the HPT can be optimally configured for almost any carrier and even for transportation of two pallets laid end to end. The ergonomic design of the tiller enables fatigue-free operation, guaranteeing outstanding levels of productivity, whilst the maximum steering lock of 205° provides extremely high

manoeuvrability - even in the tightest of spaces. The option of the quick lifting function for loads of up to 150 kg makes the HPT 25 your ideal partner for swiftly loading and unloading lorries, moving pallets, and covering short transport routes. The HPT 20 FL flat pallet truck has a lifting capacity of 2,000 kg. With a fork height of just 56.5 mm, it is best suited to lifting really low carriers, such as special pallets or packages. The tips of the forks taper towards the front, so they can be used as a skid lift, thereby making it easier to pick up pallets from the side.

High flexibility in use

Mobile workbench - whenever and wherever

Excellent stability, even at the maximum lift height



HPT 10 XM

With a lifting capacity of 1,000 kg, the HPT 10 XM manual scissor lift truck combines the advantages of a low lift pallet truck with those of a mobile workbench. The scissor lift for heights of up to 800 mm allows for loading and unloading, order picking and assembly work to

be carried out without strenuous bending or lifting. For a lift height of 400 mm or more, supports are placed on the floor to provide the equipment with stability, making the HPT 10 XM a practical and extremely safe partner.

Ergonomic operation in all situations

Lifting and lowering of loads with ease at the touch of a button

Powerful 1.6 kW lifting motor for loads of up to 1,000 kg as standard



HPT 10 XE

The HPT 10 XE allows for ergonomically optimised operation in all situations thanks to its easy-to-use electrical scissor lift function. The standard 1.6 kW lifting motor, complete with powerful 12 V/60 Ah battery, makes it possible to lift loads weighing up to 1,000 kg with

ease. The working height of up to 800 mm is freely adjustable by electrically operating the scissor lift, taking the strain off the back, and the built-in supports can be used from heights of 400 mm, providing maximum safety with the HPT 10 XE as standard.

Compliance with the most stringent hygiene standards

Quick and straightforward cleaning thanks to dirt-repellent properties

Long-lasting protection against moisture thanks to the corrosion-resistant pump mechanism



HPT 25 GA

The galvanised version HPT 25 GA has been developed for use in damp or cool operating conditions. The surface coating provides the hand pallet truck with particularly effective protection against corrosion and wear, making it ideal for use outdoors, e. g. in horticultural enterprises, covered markets or ports.

HPT 25 ST

The HPT 25 ST is made from acid-resistant stainless steel (AISI 304) and complies with all hygiene regulations from the pharmaceutical, food and chemical industries. Its electropolished surfaces are dirt-repellent, making the product easy to clean. Made from durable bronze, the pump mechanism provides effective protection against corrosion, whilst the roller bearings are fully encapsulated to keep them waterproof.

Transportation and accurate weighing of goods

Splash-proof LCD display unit suitable for use indoors and outdoors

Display and weighing unit that can be flexibly configured



HPS 20 W/25 W

Weighing, checking and calculating – the HPS 20 W and HPS 25 W variants can be used to transport loads of up to 2,000 kg and 2,500 kg respectively, whilst an accurate weight measurement can be taken in the same process step. Weighing cells built into the forks guarantee precise measurement results, with a tolerance of just 0.1% of the lifted load. The weighing unit is intuitive and easy to operate, providing supporting functions, such as stored total sum function with consecutive numbering, the option to manually pre-set tare values and taring at the press of a button. The weighing unit has been awarded protection class IP 65 due to its protection against dust and moisture. There is also a battery indicator to show the current level of charge. The optional foot brake provides for an even higher level of safety on ramps, whilst the built-in printer – another optional feature – allows this one product to take care of yet another process step.

The HPS 20 W can weigh loads of up to 2,000 kg, and is mainly used in dispatch or goods inwards areas to determine transport weights in order to check for overloading or to run estimated checks of incoming goods. The scales come with an LCD display showing weights in 1 kg steps, and the weighing equipment is powered by four 1.5 V AA batteries.

The HPS 25 W features a multi-range display as standard for weighing goods. For loads of up to 200 kg, the weight is displayed in 0.2 kg steps, which allows for accurate measurements to be taken. The product is also almost always ready for use, as the battery module is easy to replace.

In industrial use, the HPS 25 W is suitable for loads of up to 2,500 kg, e. g. for checking weights in production and when measuring consumable materials or filling containers. Additional functions for counting pieces by entering or calculating the piece weight, a date/time function and a calibrated version are also available as options.

High manoeuvrability due to large steering angle

Easy crossways loading of pallets thanks to loading rollers under the tips of the forks

Ergonomically optimised tiller shape for fatigue-free operation



HPS and HPT

With lifting capacities of between 1,000 kg and 3,000 kg, the HPS and HPT hand pallet trucks are incredibly versatile with applications for production, retail, logistics service providers and workshops, where they can be relied upon to manoeuvre in the tightest of spaces, transport goods or load and unload lorries. These products feature a robust steel construction that has been designed with durability in mind, boasting torsional rigidity and proving ideal for even the most heavy-duty of applications. Their compact design, various fork sizes and

load capacities allow these hand lift trucks to be adapted to suit the particular application in question perfectly. The HPS 25 and its standard quick lifting function make it possible for loads of up to 200 kg to be lifted with even more speed, resulting in better handling performance. Thanks to the extensive range of tyre options available, the rollers can be adapted to the ground conditions to ensure optimum rolling performance.

The 'Simply Efficient' factors: Performance attributes as a measure of economic efficiency

Simply easy

- Optimised tiller handle shape and functionality for guaranteed fatigue-free operation
- Effortless – electrical lifting and lowering of loads, meaning physical strain is kept to a minimum
- Easier and quicker crossways loading of pallets thanks to the loading and unloading guides
- Fuel savings thanks to suitable tyre options that guarantee optimal grip and minimum rolling resistance in all situations

Simply powerful

- Effective goods handling with the capacity to transport goods weighing up to 3,000 kg
- Torsionally rigid steel construction guaranteeing durability and reliability for demanding applications
- Low wear thanks to powder-coated surfaces
- Powerful motion with the manual or electrical scissor lift function making it possible to lift loads of up to 1,000 kg to a height of up to 800 mm
- Even better handling performance for loads of up to 200 kg with the HPS 25's quick lifting function as standard

Simply safe

- Ergonomic operation with lift heights of up to 800 mm
- Safe handling of delicate goods with high-precision lowering of the forks
- Optional operating and parking brake ensures safety even on ramps
- Improved safety thanks to supports that can be used for lift heights of 400 mm or more
- Hydraulic overload protection to prevent errors and guarantee correct usage
- Splash-proof display unit for scales for use outdoors

Simply flexible

- Various fork lengths and widths available to ensure you have the right equipment for every requirement
- Exceptional manoeuvrability even in the tightest of spaces due to the tiller's large steering angle



Easy crossways loading of pallets thanks to the tandem roller with loading guide



Versatile and extendable – accurate weighing equipment for a wide range of operational requirements



Low steering forces and rolling resistance thanks to the single nylon roller



Pick up extremely low special pallets with the HPT 20 FL's flat forks

Equipment Variants

		HPS 20 HPS 25	HPS 20 W	HPS 25 W	HPT 25 HPT 30	HPT 20 FL	HPT 25 GA HPT 25 ST	HPT 10 XM	HPT 10 XE
General	Various fork lengths	—	—	○	○	—	—	—	—
	Various equipment widths	—	—	○	○	—	—	—	—
Wheels	Steering wheel tyres, nylon	●	—	—	●	●	●	●	●
	Steering wheel tyres, polyurethane	○	—	—	○	○	—	○	○
	Steering wheel tyres, solid rubber	○	●	●	○	○	—	○	○
	Steering wheel tyres, polyurethane	—	○	○	—	—	—	—	—
	Load roller tyres, nylon, single	●	—	—	●/—	—	●	—	—
	Load roller tyres, nylon, tandem	—/○	—	—	○/●	—	○/—	—	—
	Load roller tyres, polyurethane, single	○	—	—	○/—	—	—	●	●
Safety	Load roller tyres, polyurethane, tandem	○	●	●	○	—	—	—	—
	Operating and parking brake (using the lever)	—	—	—	○	—	—	—	—
Battery system	Parking brake (using the foot pedal)	—	○	○	—	—	—	—	—
	12 V/60 Ah battery for the electrical lifting equipment, including external charger	—	—	—	—	—	—	—	●
	12 V/1.2 Ah replacement battery for operating the weighing display, including external charger	—	—	●	—	—	—	—	—
Additional equipment	4 x 1.5 V AA batteries for operating the weighing display	—	●	—	—	—	—	—	—
	Quick lifting function for loads of up to 150 kg	—	—	—	○/—	—	—	●	—
	Quick lifting function for loads of up to 200 kg	—/●	●	●	—	—	—	—	—
	Weighing system for measuring up to 2,000 kg	—	●	—	—	—	—	—	—
	Weighing system for measuring up to 2,500 kg	—	—	●	—	—	—	—	—
	Weighing system for measuring up to 2,500 kg, can be calibrated	—	—	○	—	—	—	—	—
	Built-in printer for weighing system	—	○	○	—	—	—	—	—
	Manual scissor lift	—	—	—	—	—	—	●	—
Electrical scissor lift	—	—	—	—	—	—	—	●	

● Standard ○ Optional — Not available

STILL GmbH
Berzeliusstr. 10
22113 Hamburg
Germany

Tel.: +49 40 73 39 20 00

Fax: +49 40 73 39 20 01

info@still.de

For further information please visit

www.still.eu



Gemini Equipment And Rentals Pvt. Ltd.

1706-1709, The Corporate Park 17th Floor Plot No-14-15
Vashi Navi Mumbai -400705, India.
Email id : info@gear-india.com | Contact No: +918451934343 |
Website: www.gear-india.com

STILL is certified in the following areas: Quality management, occupational safety, environmental protection and energy management.

